

EE 508

Lecture 23

Filter Synthesis Strategies

- Integrators

Review from last time

Sensitivity Comparisons

Consider 5 second-order lowpass filters

(all can realize same $T(s)$ within a gain factor)

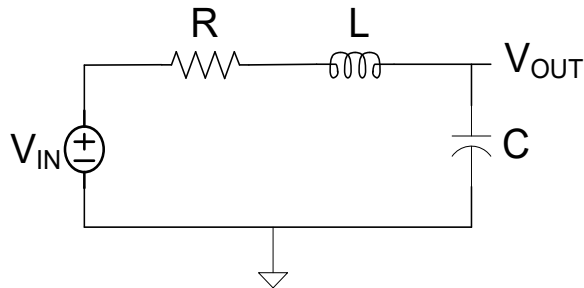

Passive RLC

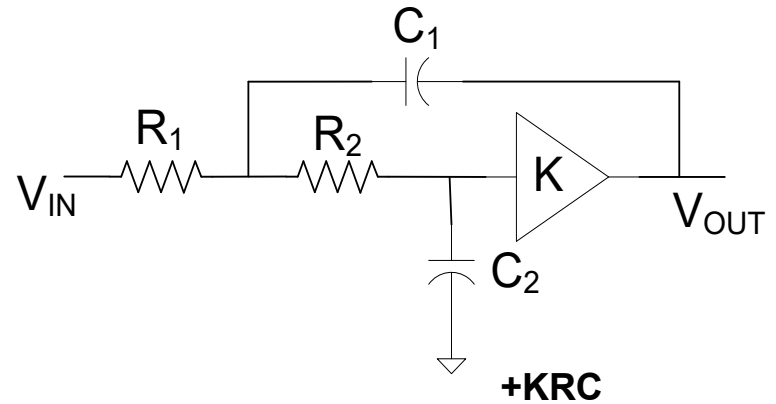

$+KRC$

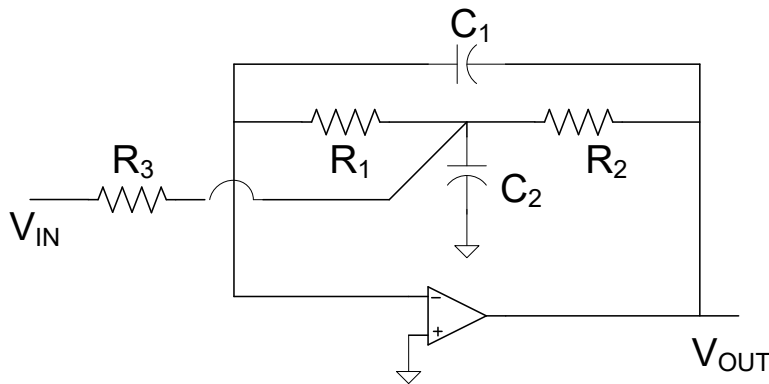

Bridged-T Feedback

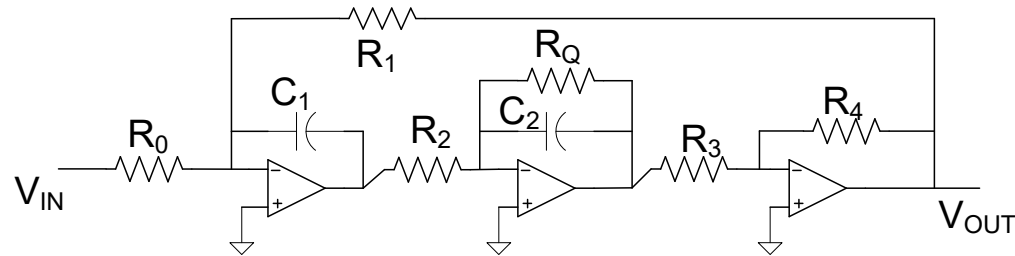

Two-Integrator Loop

Review from last time

Sensitivity Comparisons

Consider 5 second-order lowpass filters

(all can realize same $T(s)$ within a gain factor)

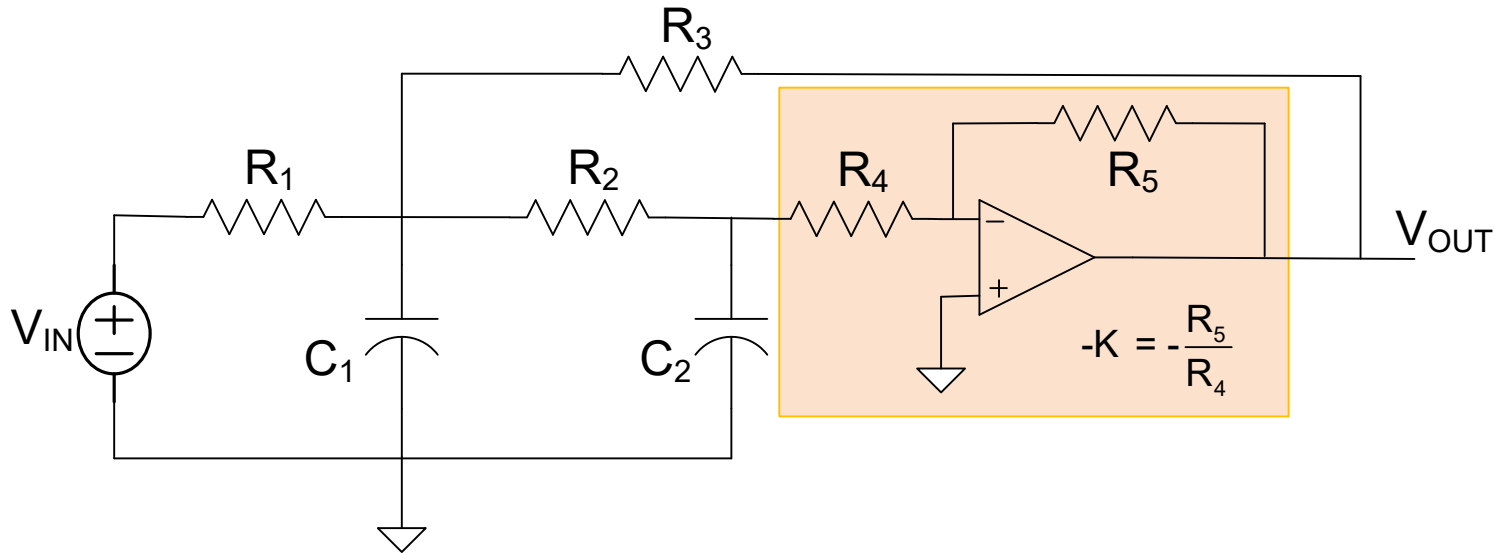

-KRC Lowpass

Review from last time

Relationship between active pole sensitivities and ω_0 and Q sensitivities

Define $D(s) = D_0(s) + t D_1(s)$ (from bilinear form of $T(s)$)

Recall:
$$s_\tau^p = \frac{-D_1(p)}{\left. \frac{\partial D(s)}{\partial s} \right|_{s=p, t=0}}$$

Theorem:
$$\Delta p \cong \tau s_\tau^p$$

Theorem:
$$\Delta \alpha \cong \tau \operatorname{Re}(s_\tau^p)$$
$$\Delta \beta \cong \tau \operatorname{Im}(s_\tau^p)$$

Theorem:

$$\frac{\Delta \omega_0}{\omega_0} \cong \frac{1}{2Q} \frac{\Delta \alpha}{\omega_0} + \sqrt{1 - \frac{1}{4Q^2}} \frac{\Delta \beta}{\omega_0} \qquad \frac{\Delta Q}{Q} \cong -2Q \left(1 - \frac{1}{4Q^2} \right) \frac{\Delta \alpha}{\omega_0} + \sqrt{1 - \frac{1}{4Q^2}} \frac{\Delta \beta}{\omega_0}$$

Claim: These theorems, with straightforward modification, also apply to other parameters (R, C, L, K, ...) where, $D_0(s)$ and $D_1(s)$ will change since the parameter is different

Review from last time

Are these passive sensitivities acceptable?

$$\left| S_x^{\omega_0} \right|$$

$$\left| S_x^Q \right|$$

Passive RLC

$$\leq \frac{1}{2}$$

$$1, 1/2$$

+KRC

Equal R, Equal C (K=3-1/Q)

$$0, 1/2$$

$$Q, 2Q, 3Q$$

Equal R, K=1 (C₁=4Q²C₂)

$$0, 1/2$$

$$0, 1/2, 2Q^2$$

Bridged-T Feedback

$$0, 1/2$$

$$1/3, 1/2, 1/6$$

Two-Integrator Loop

$$0, 1/2$$

$$1, 1/2, 0$$

-KRC

less than or equal to 1/2

less than or equal to 1/2

Are these active sensitivities acceptable?

Active Sensitivity Comparisons

Passive RLC

$$\frac{\Delta\omega_0}{\omega_0}$$

$$\frac{\Delta Q}{Q}$$

+KRC

Equal R, Equal C ($K=3-1/Q$)

$$-\frac{1}{2}\left(3-\frac{1}{Q}\right)^2 \tau\omega_0$$

$$-\frac{1}{2}\left(3-\frac{1}{Q}\right)^2 \tau\omega_0$$

Equal R, $K=1$ ($C_1=4Q^2C_2$)

$$-Q\tau\omega_0$$

$$Q\tau\omega_0$$

Bridged-T Feedback

$$-\frac{3}{2}Q\tau\omega_0$$

$$\frac{1}{2}Q\tau\omega_0$$

Two-Integrator Loop

$$-\tau\omega_0$$

$$4Q\tau\omega_0$$

-KRC

$$\frac{5}{2}Q\tau\omega_0$$

$$25Q^3\tau\omega_0$$

Review from last time

Are these sensitivities acceptable? Review from last time

Passive Sensitivities:

$$\frac{\Delta\omega_0}{\omega_0} \cong S_x^{\omega_0} \frac{\Delta x}{x}$$

In integrated circuits, $\Delta R/R$ and $\Delta C/C$ due to process variations can be K 30% or larger due to process variations

Many applications require $\Delta\omega_0/\omega_0 < .001$ or smaller and similar requirements on $\Delta Q/Q$

Even if sensitivity is around $1/2$ or 1, variability is often orders of magnitude too large

Active Sensitivities:

All are proportional to $\tau\omega_0$

Some architectures much more sensitive than others

Can reduce $\tau\omega_0$ by making GB large but this is at the expense of increased power and even if power is not of concern, process presents fundamental limits on how large GB can be made

What can be done to address these problems?

1. Predistortion

Design circuit so that after component shift, correct pole locations are obtained

Predistortion is generally used in integrated circuits to remove the bias associated with inadequate amplifier bandwidth

Predistortion does not help with process variations of passive components

Tedious process after fabrication since depends on individual components

Temperature dependence may not track

Difficult to maintain over time and temperature

Over-ordering will adversely affect performance

Seldom will predistortion alone be adequate to obtain acceptable performance

Bell Labs did to this in high-volume production (STAR Biquad)

What can be done to address these problems?

1. Predistortion

Design circuit so that after component shift, correct pole locations are obtained

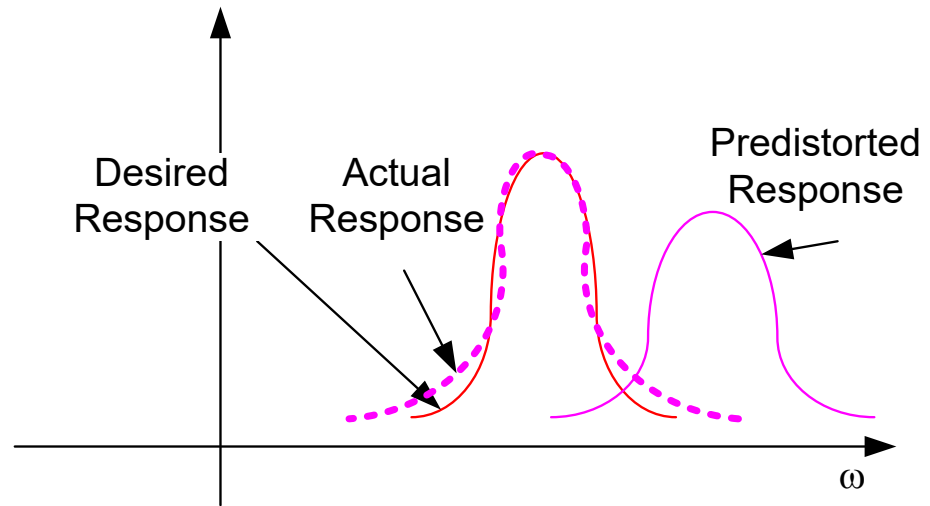
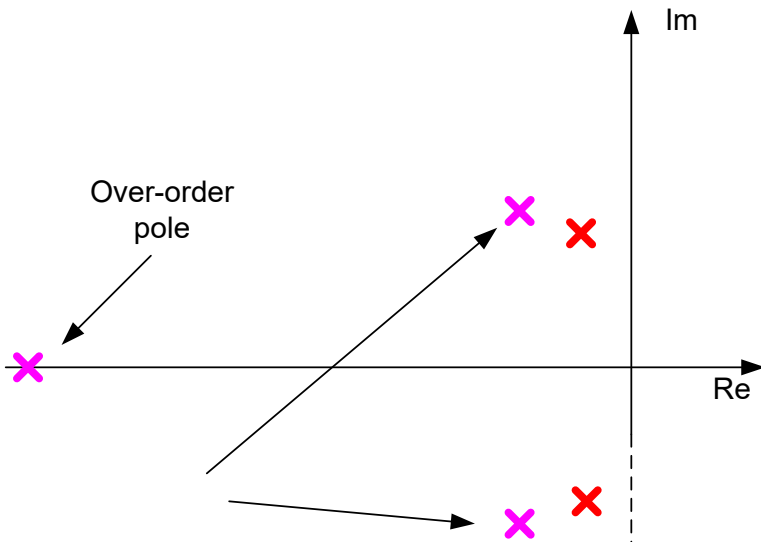

Over-ordering Limitations with Pre-distortion

Parasitic Pole Affects Response

Predistortion almost always done even if benefits only modest

Not effective if significant deviations exist before predistortion

What can be done to address these problems?

2. Trimming

a) Functional Trimming

- trim parameters of actual filter based upon measurements
- difficult to implement in many structures
- manageable for cascaded biquads

b) Deterministic Trimming (much preferred)

- Trim component values to their ideal value
 - Continuous-trims of resistors possible in some special processes
 - Continuous-trim of capacitors is more challenging
 - Link trimming of Rs or Cs is possible with either metal or switches
- If all components are ideal, the filter should also be ideal
 - R-trimming algorithms easy to implement
 - Limited to unidirectional trim
 - Trim generally done at wafer level for laser trimming, package for link trims
- Filter shifts occur due to stress in packaging and heat cycling

c) Master-slave reference control (depends upon matching in a process)

- Can be implemented in discrete or integrated structures
- Master typically frequency or period referenced
- Most effective in integrated form since good matching possible
- Widely used in integrated form

Master-slave Control (depends upon matching in a process)

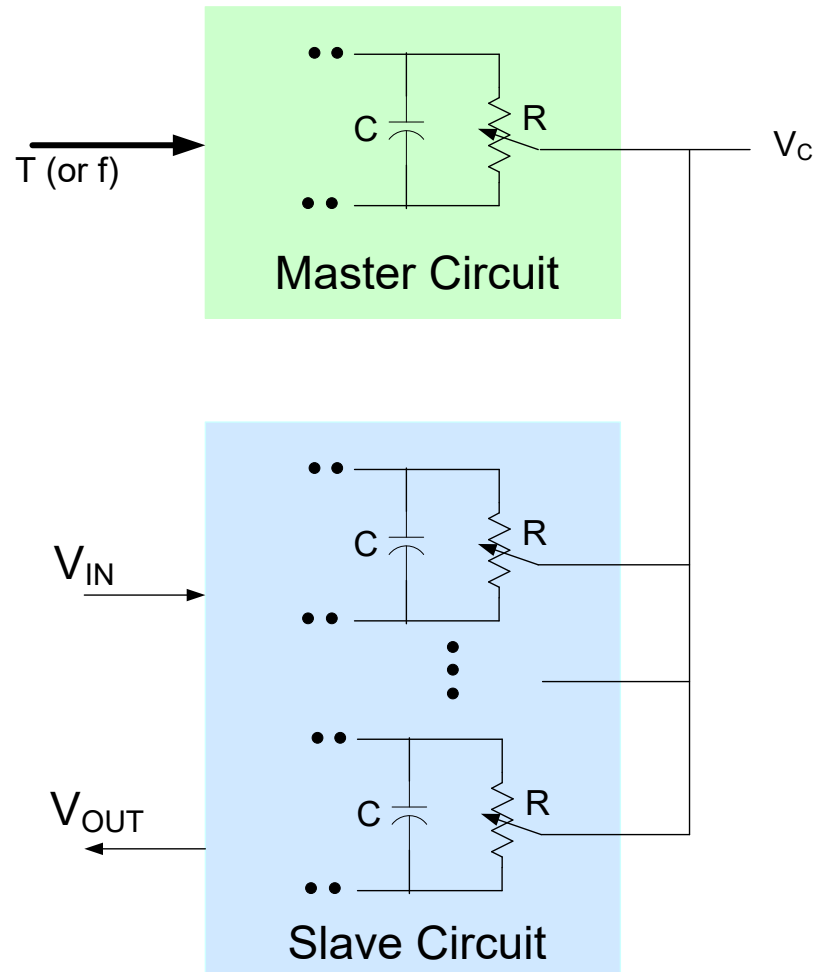

- Automatically adjust R (or C) in the Master Circuit to match RC to T
- Rely on matching to match RC products in Slave Circuit to T
- Matching can be very good (1% or 0.1% or better)
- But does nothing to compensate for local random variations

Master-slave Example:

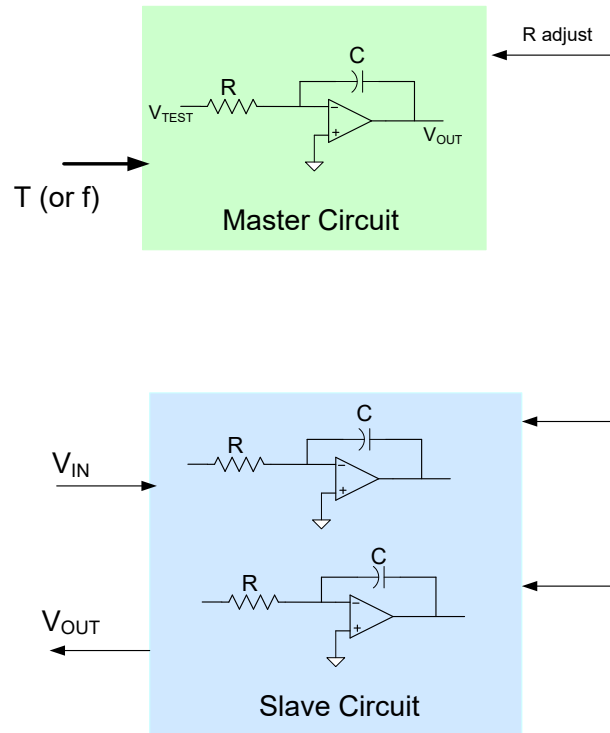

$$T(s) = \frac{V_{OUT}}{V_{TEST}} = - \frac{1}{RCs}$$

- Key parameter of integrator is unity gain frequency $I_0=1/RC$
- Adjust R in Master Circuit so that $I_0=1$ at the input frequency f
- With matching, unity gain frequency of all integrators in Slave Circuit will also be 1
- May require considerable overhead to trim circuit elements
- Compensates for combined component variations and BW limitations

Master-slave Example:

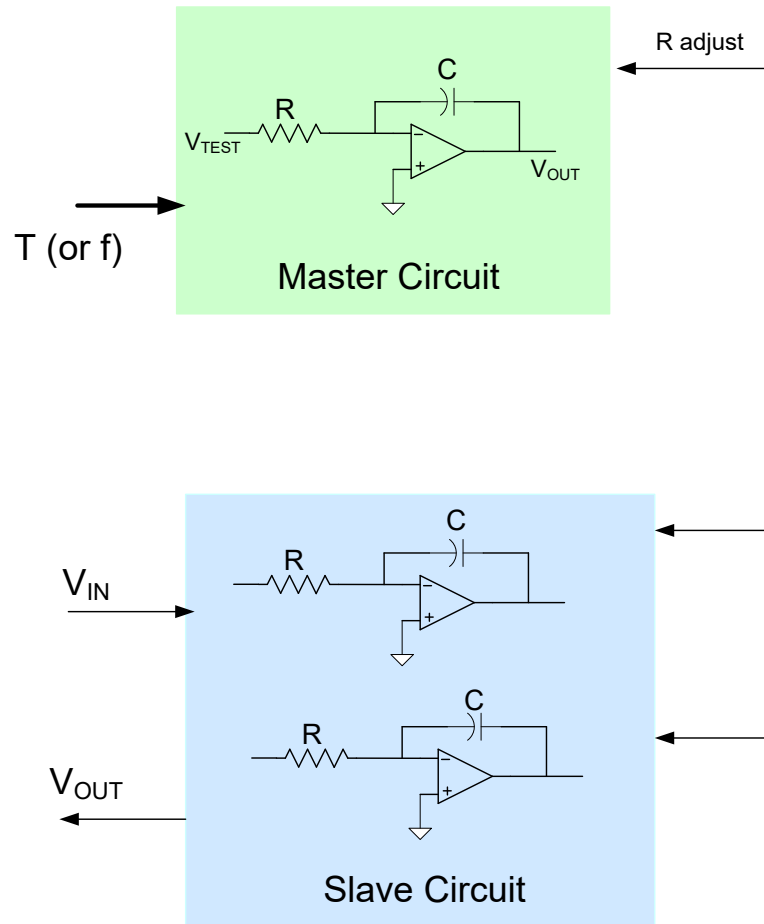

$$T(s) = \frac{V_{OUT}}{V_{TEST}} = - \frac{1}{RCs}$$

$$T_{ACT}(s) = \frac{V_{OUT}}{V_{TEST}} = - \frac{1}{RCs + \tau(s + RCs^2)}$$

- Over-ordering will limit accuracy of master-slave approach even if unity gain frequency of master circuit is precisely obtained
- Technique is often used to maintain good control of effective RC products

What can be done to address these problems?

3. Select Appropriate Architecture

Helps a lot

Best architectures are not known

Performance of good architectures often not good enough

What can be done to address these problems?

4. Different Approach for Filter Implementation

- **Frequency Referenced Filters**
 - **Switched-Capacitor Filters**
- **DSP- Based Filter Implementation**
- **Other Niche Methods**

Summary of Sensitivity Observations

- Sensitivity varies substantially from one implementation to another
- Variability too high, even with low sensitivity, for more demanding applications
- Methods of managing high variability
 - Select good structures
 - Trimming
 - Functional
 - Deterministic
 - Predistortion
 - In particular, for active sensitivities
 - Useful but not a total solution
 - Frequency Referenced Techniques
 - Master-Slave Control
 - Depends upon matching
 - Can self-trim or self-compensate
 - Switched-Capacitor Filters
 - AD/digital filter/D/A
 - Alternate Design Approach
 - Other methods

Filter Design Process

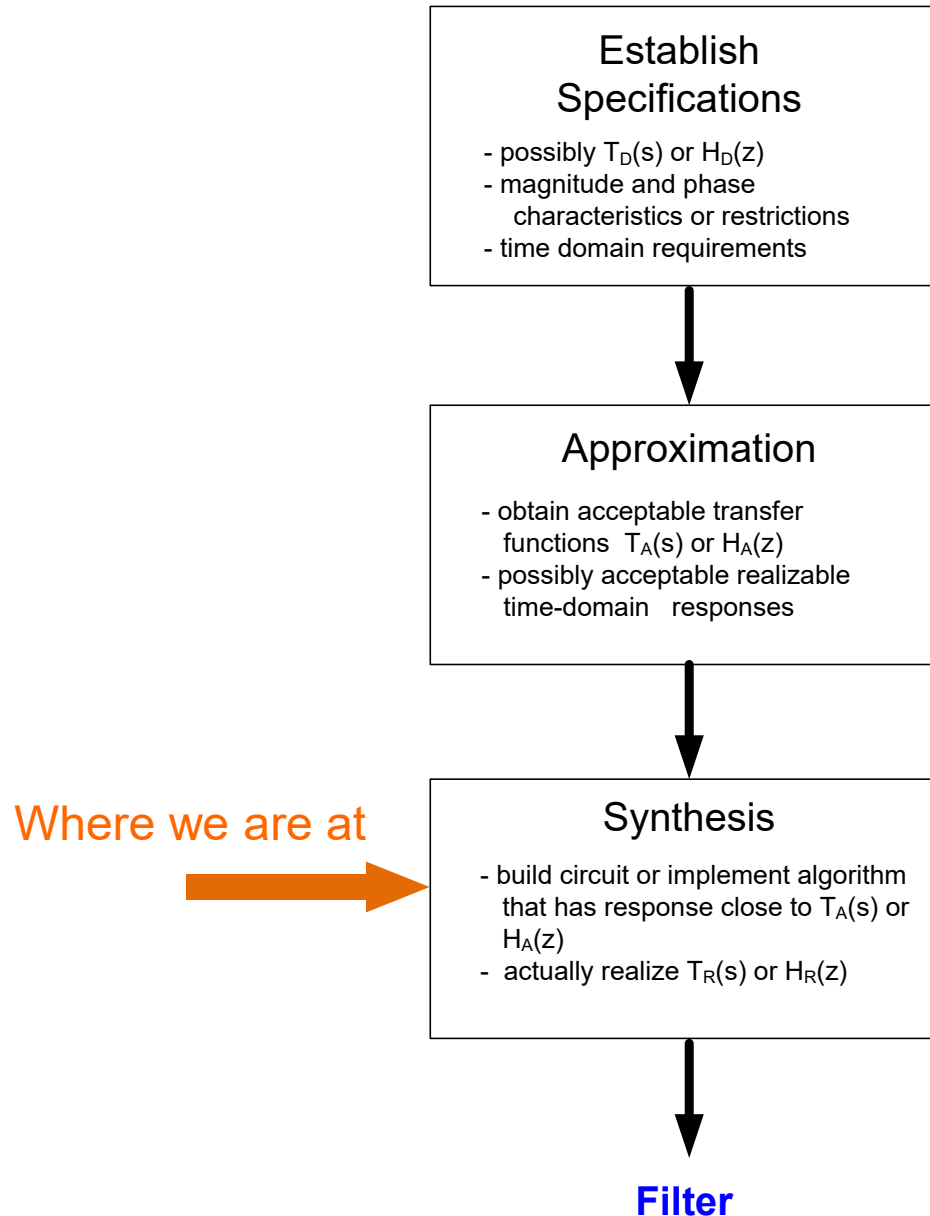

Filter Design/Synthesis Considerations

Most designs today use one of the following three basic architectures

Cascaded Biquads

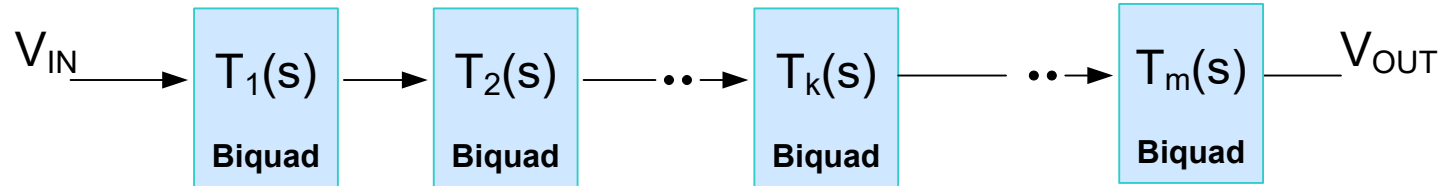

$$T(s) = T_1 T_2 \dots T_m$$

Leapfrog

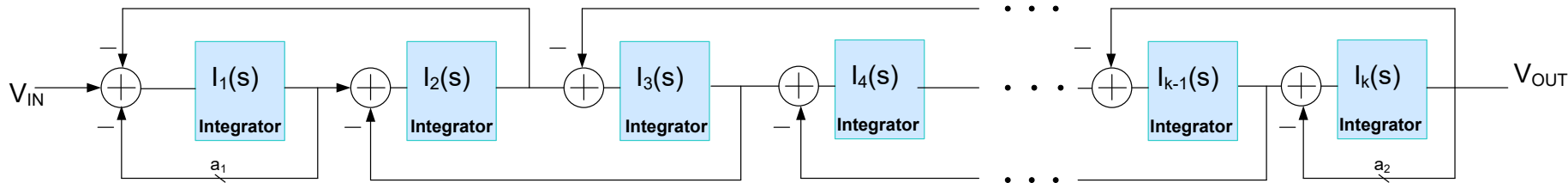

Multiple-loop Feedback – One type shown (less popular)

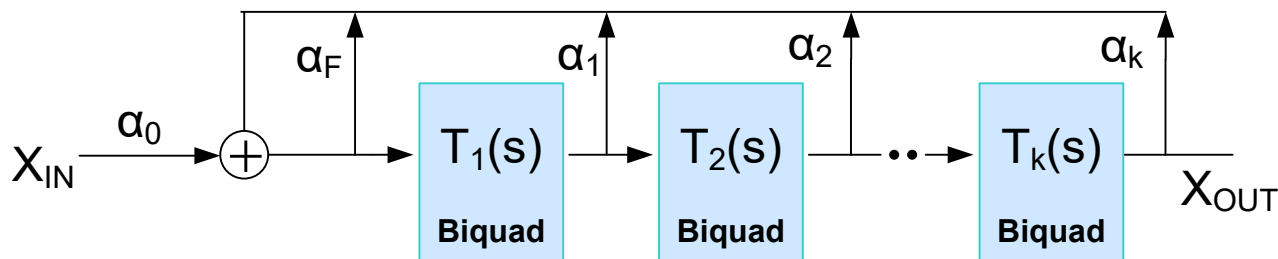

Filter Design/Synthesis Considerations

Multiple-loop Feedback – Another type

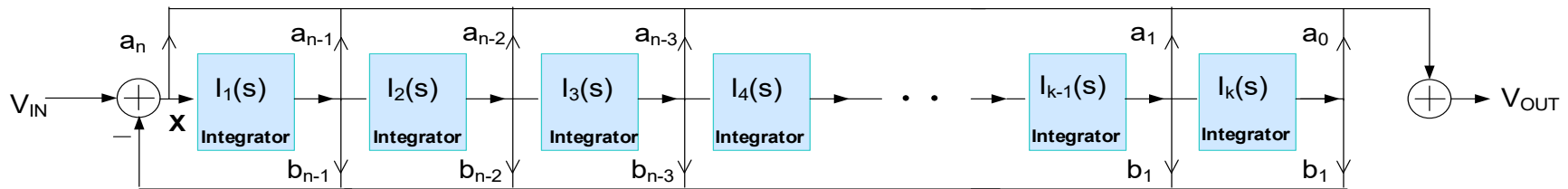

$$X = V_{IN} - X \bullet \sum_{k=1}^n b_{n-k} \left(\frac{I_0}{s} \right)^k$$

$$V_{OUT} = X \bullet \sum_{k=0}^n a_{n-k} \left(\frac{I_0}{s} \right)^k$$

$$T(s) = \frac{\sum_{k=0}^n a_{n-k} \left(\frac{I_0}{s} \right)^k}{1 + \sum_{k=1}^n b_{n-k} \left(\frac{I_0}{s} \right)^k}$$

$$T(s) = \frac{\sum_{k=0}^n a_{n-k} I_0^k s^{n-k}}{s^n + \sum_{k=1}^n b_{n-k} I_0^k s^{n-k}}$$

- Termed the direct synthesis method
- Directly implements the coefficients in the numerator and denominator
- Approach followed in the Analog Computers
- Not particularly attractive from an overall performance viewpoint

Filter Design/Synthesis Considerations

Cascaded Biquads

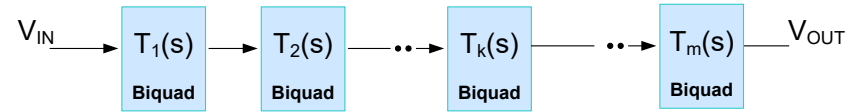

$$T(s) = T_1 T_2 \dots T_m$$

Leapfrog

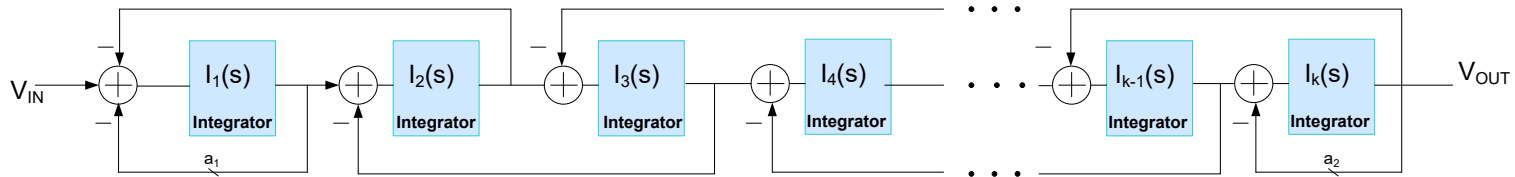

Multiple-loop Feedback – One type shown

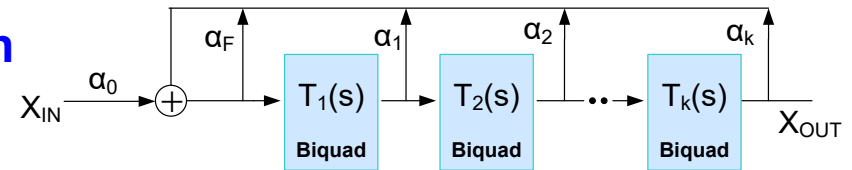

Will study details of all three types of architectures later

Observation: All filters are comprised of summers, biquads and integrators

Consider now the biquads

Biquad Filters Design Considerations

Several different Biquads were considered and other implementations exist

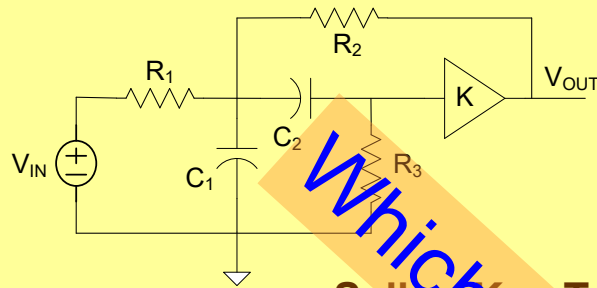

Sallen-Key Type (Dependent Sources)

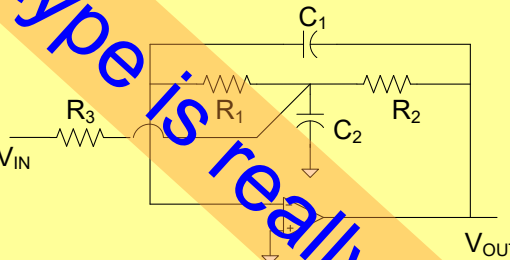
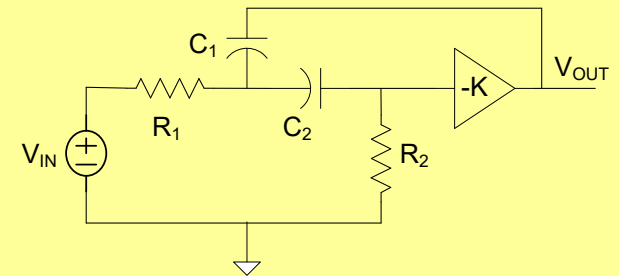

Infinite Gain Amplifiers

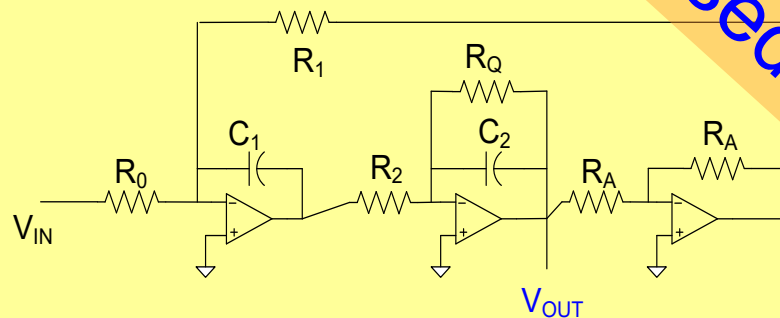

Integrator Based Structures

Which type is really used?

Floating Nodes

A node in a circuit is termed a **floating node** if it is not an output node of a ground-referenced voltage-output amplifier (dependent or independent), not connected to a ground-referenced voltage source, or not connected to a ground-referenced null-port

● Floating Node

● Not Floating Node

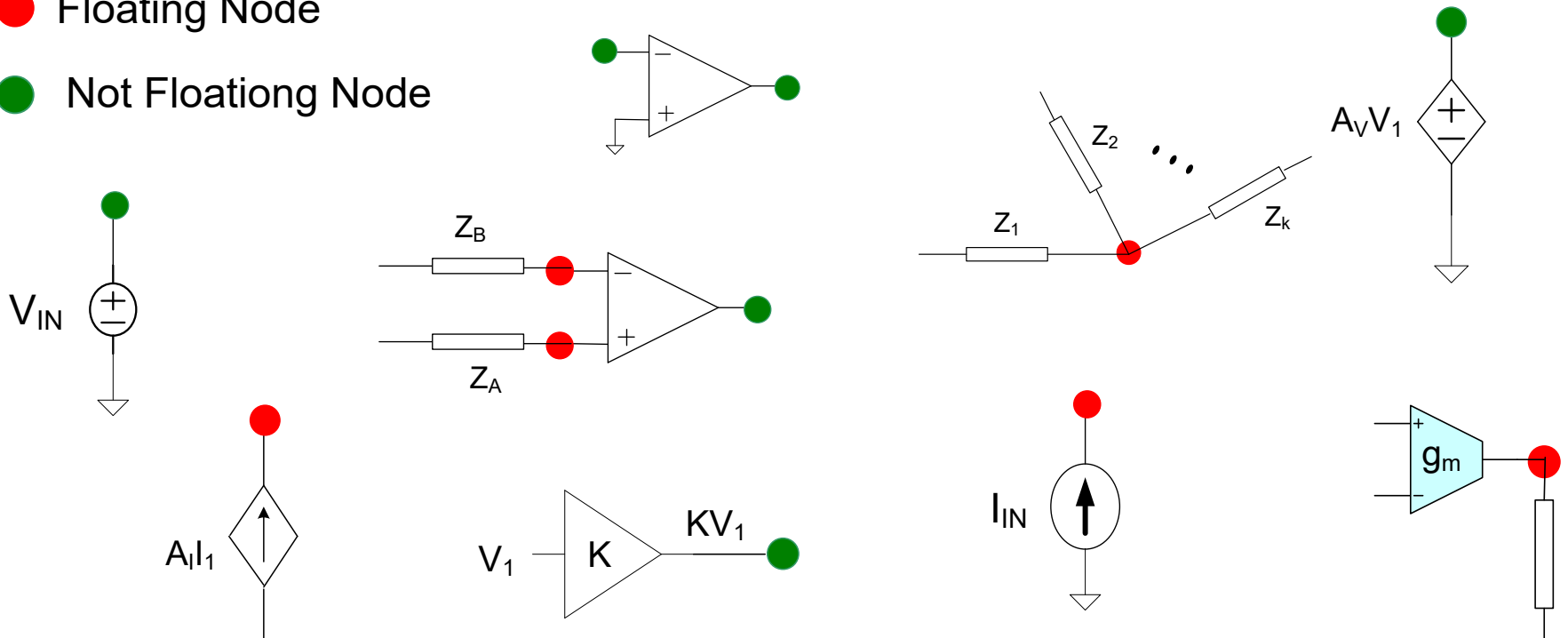

Parasitic Capacitances on Floating Nodes

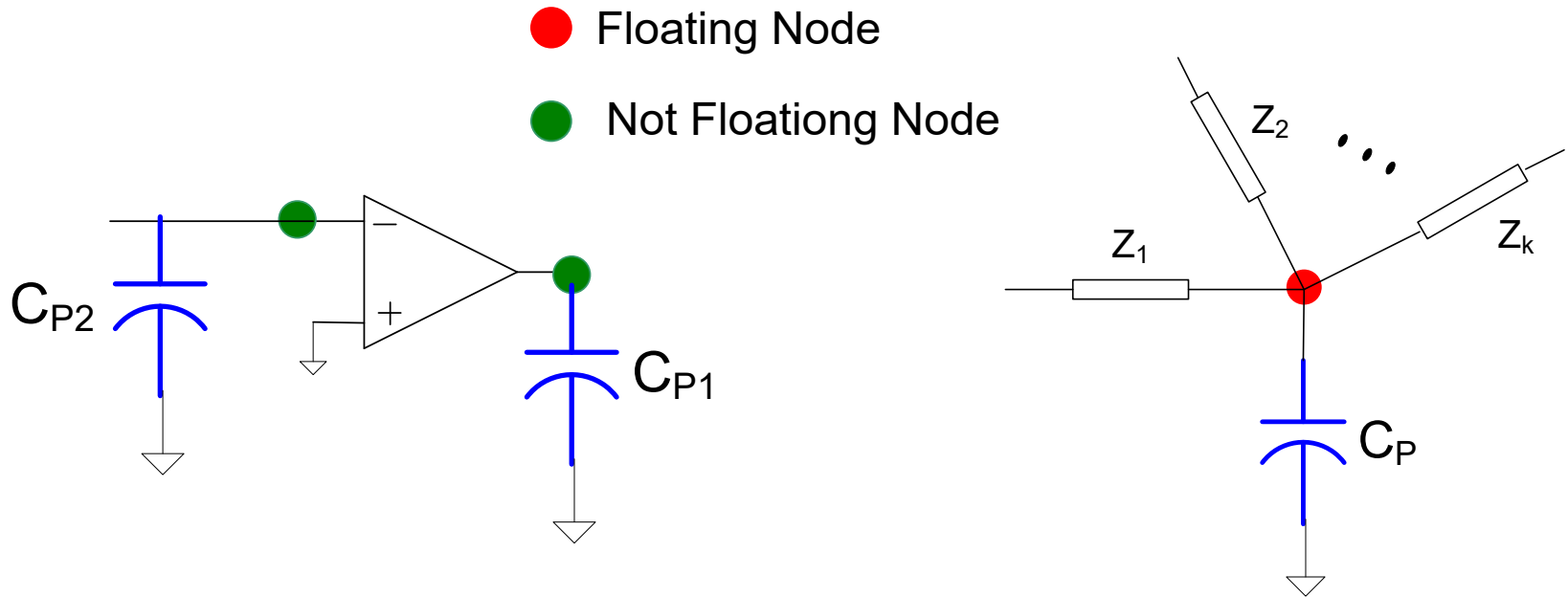

Parasitic capacitances ideally have no effect on filter when on a non-floating node but directly affect transfer function when they appear on a floating node

Parasitic capacitances are invariably large, nonlinear, and highly process dependent in integrated filters. Thus, it is difficult to build accurate integrated filters if floating nodes are present

Generally avoid floating nodes, if possible, in integrated filters

Which type of Biquad is really used?

● Not Floating Node

● Floating Node

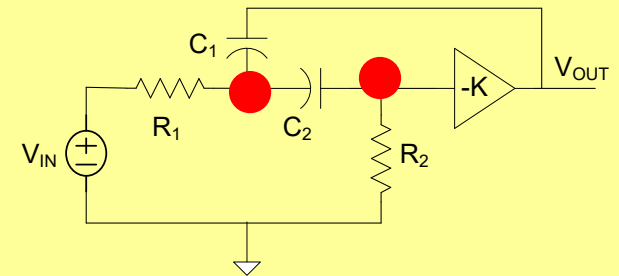
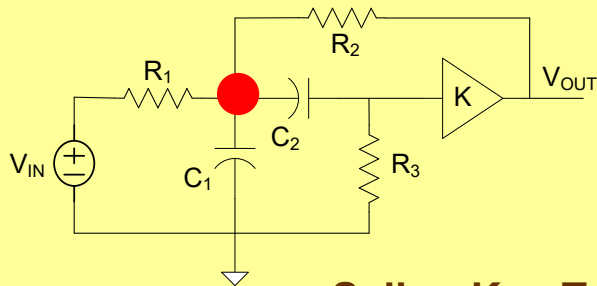

Sallen-Key Type (Dependent Sources)

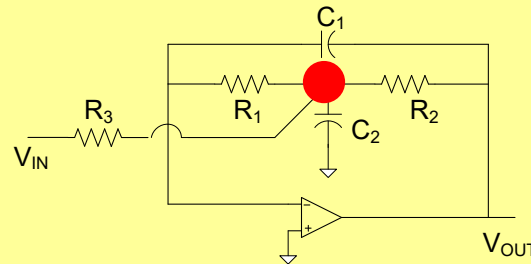

Infinite Gain Amplifiers

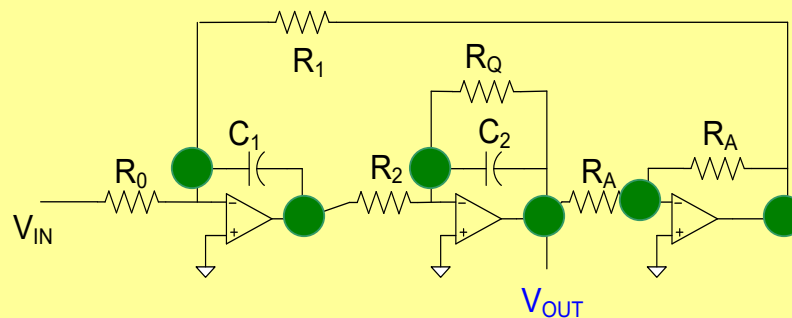

Integrator Based Structures

Which type of Biquad is really used?

● Not Floating Node

● Floating Node

Integrator-based structures with no floating nodes dominantly used in integrated filters with floating nodes are used

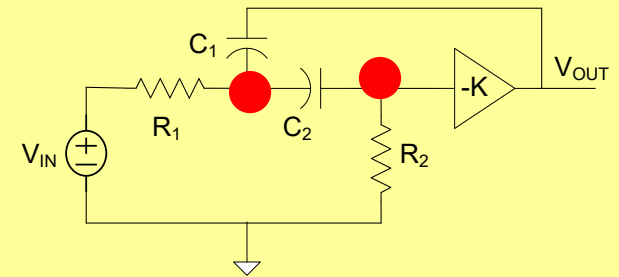

(Dependent Sources)

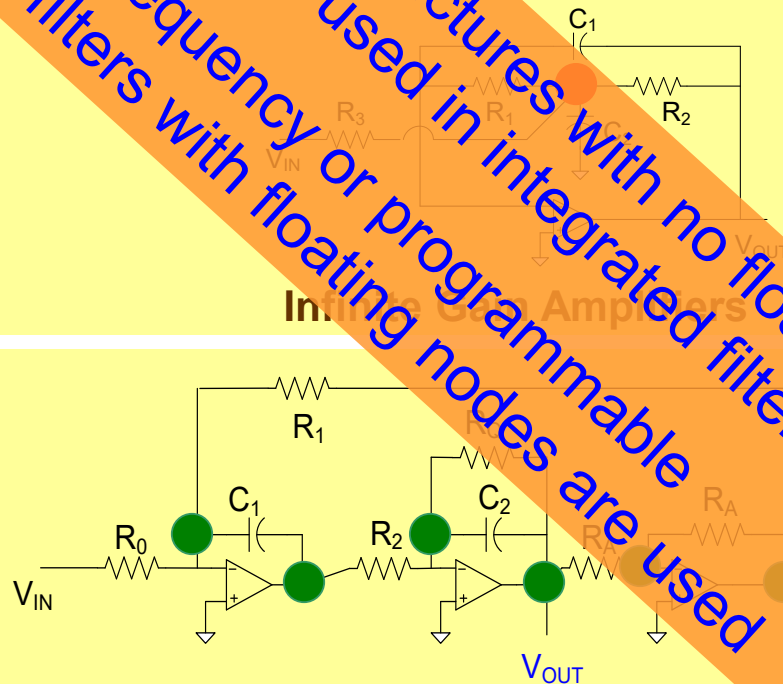

Integrator Based Structures

Integrator-based Biquads

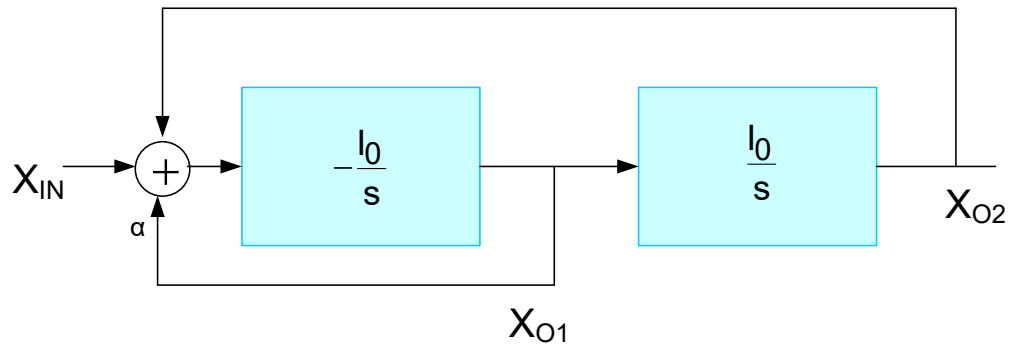
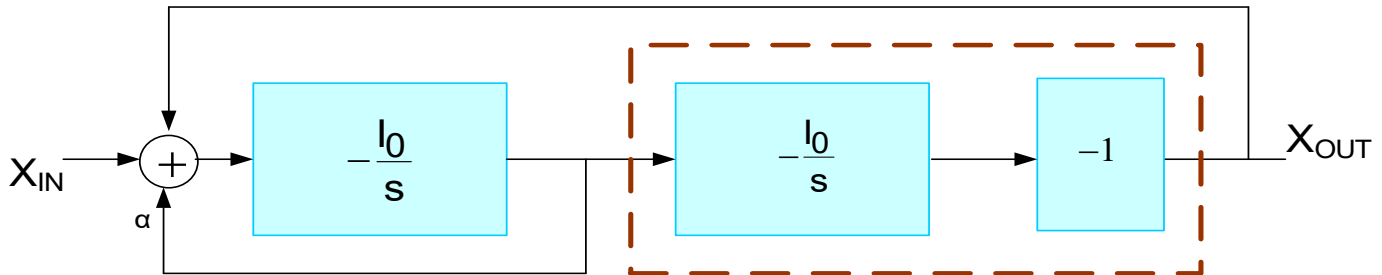
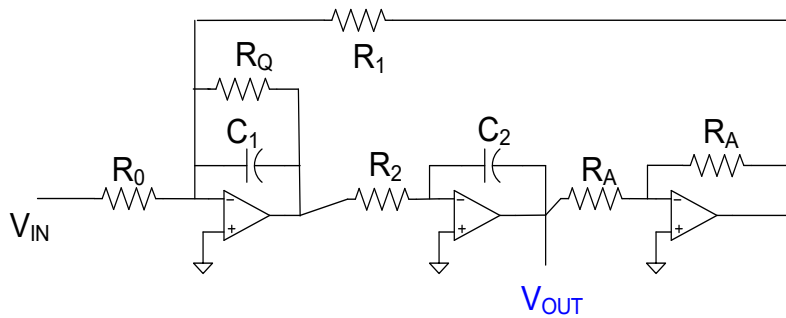

Integrator-based Biquads

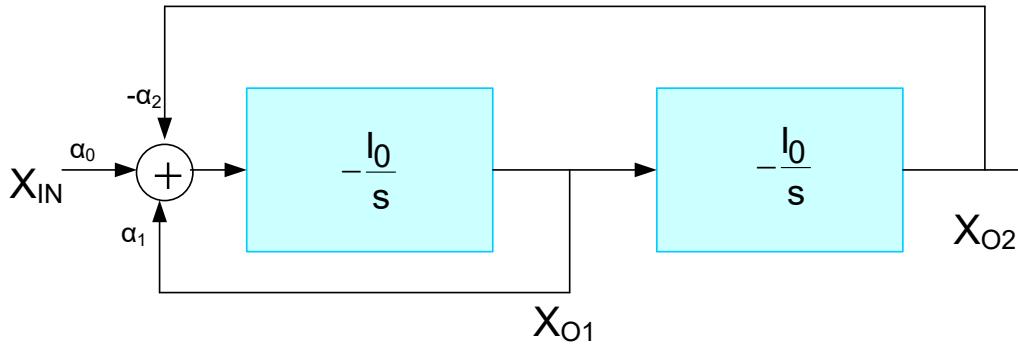

State Variable Biquad
(Alt KHN Biquad)

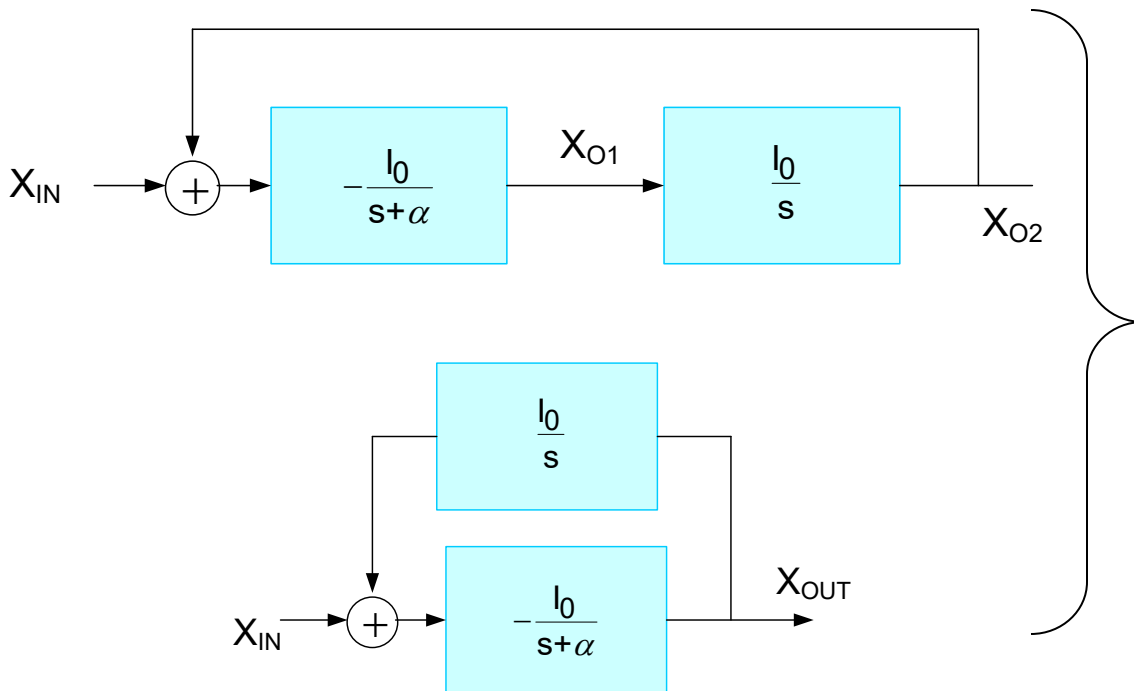

Integrator and lossy
integrator in a loop

Integrator-based Biquads

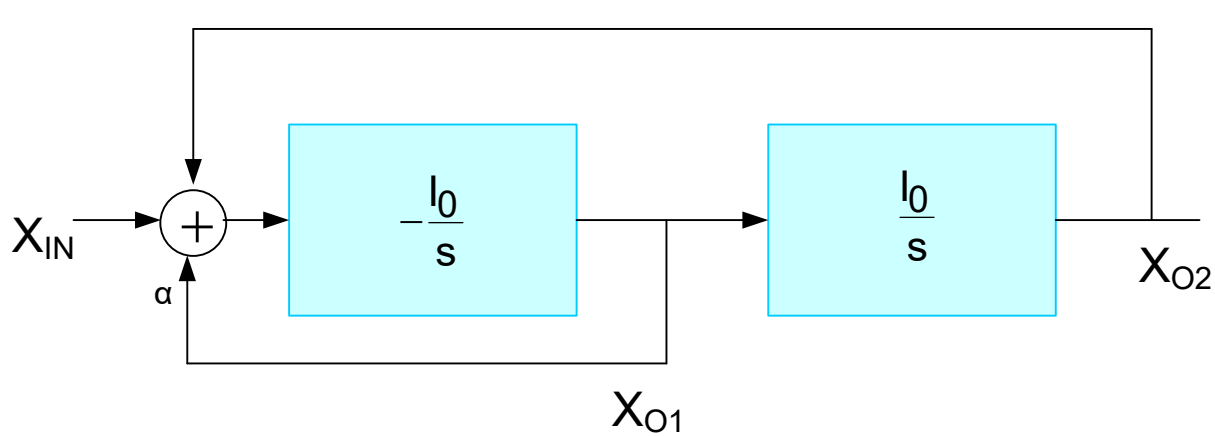

Tow-Thomas Biquad

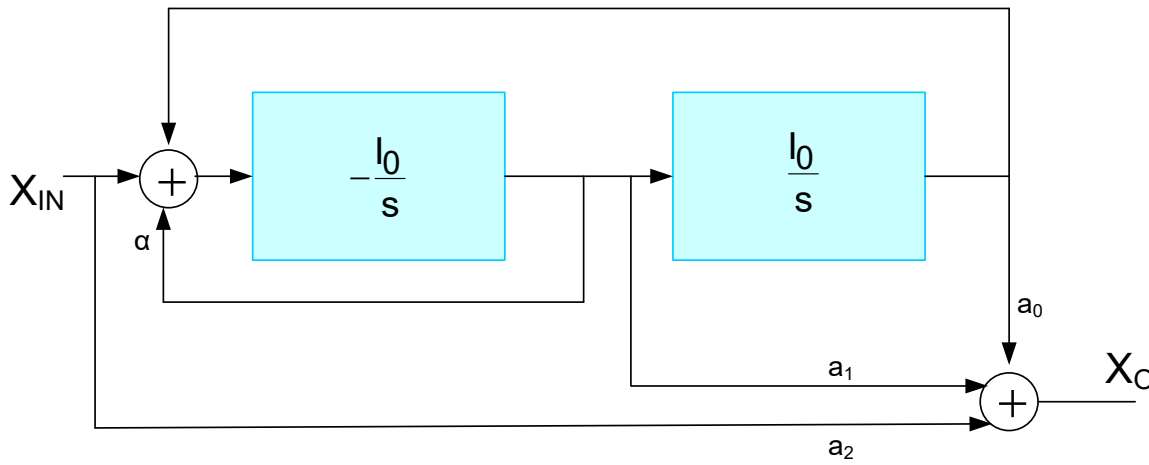

With arbitrary zero locations

Integrator-based Biquads

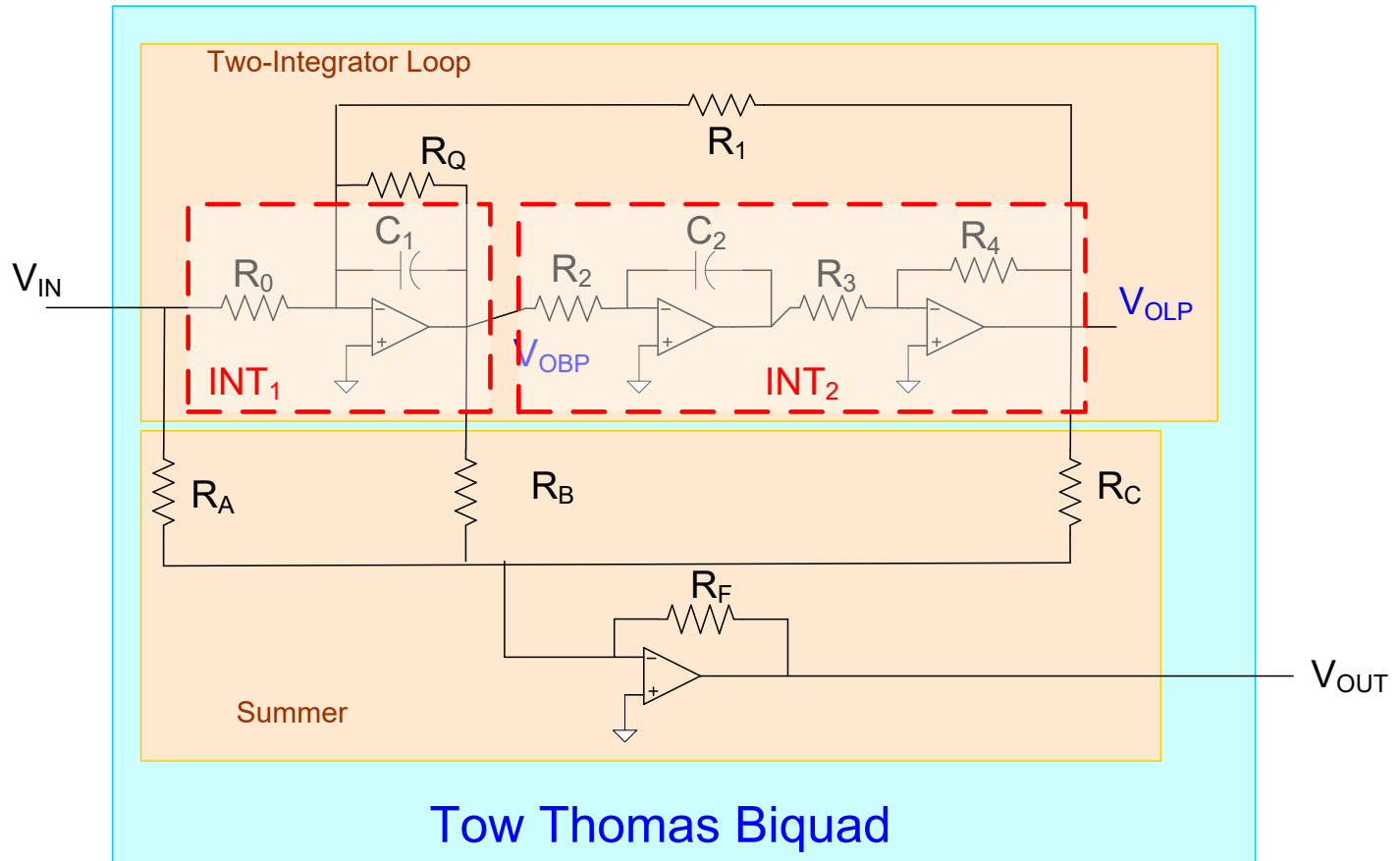
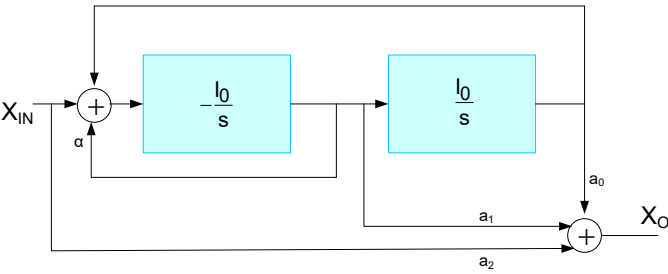

Integrator-based Biquads

- Integrator-based biquads all involve two integrators in a loop
- All integrator-based biquads discussed have no floating nodes
- Most biquads in integrated filters are based upon two integrator loop structures
- The summers are usually included as summing inputs on the integrators
- The loss can be combined with the integrator to form a lossy integrator
- Performance of the minor variants of the two integrator loop structures are comparable

Filter Design/Synthesis Considerations

Cascaded Biquads

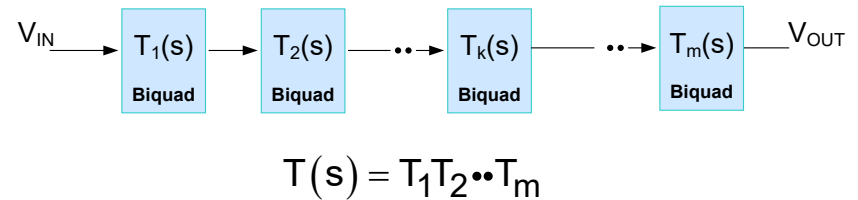

Leapfrog

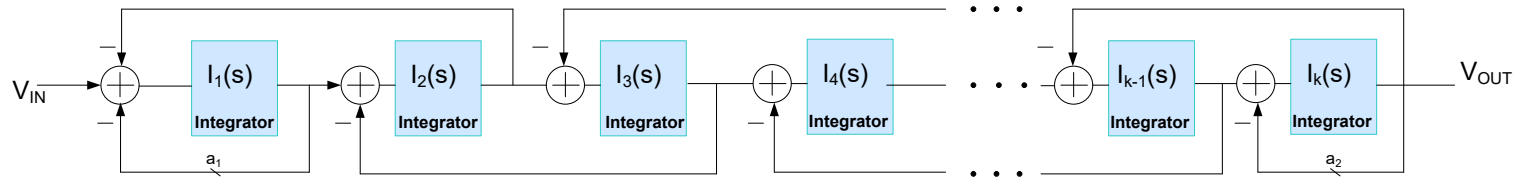

Multiple-loop Feedback – One type shown

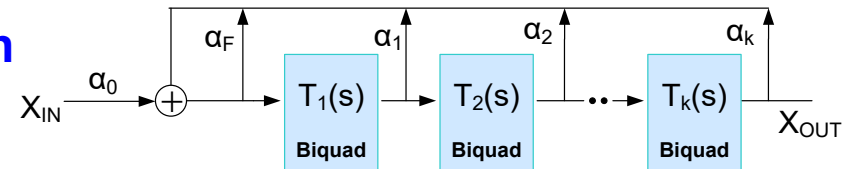

Observation: All filters are comprised of summers, biquads and integrators

And biquads usually made with summers and integrators

Integrated filter design generally focused on design of integrators, summers, and amplifiers (Op Amps)

Will now focus on the design of integrators, summers, and op amps

Basic Filter Building Blocks

(particularly for integrated filters)

- • Integrators
 - Summers
 - Operational Amplifiers
- 

Integrator Characteristics of Interest

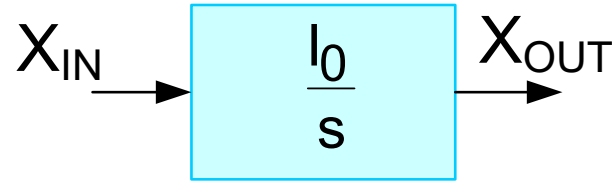

$$I(s) = \frac{I_0}{s}$$

Properties of an ideal integrator:

$$|I(j\omega)| = \frac{I_0}{\omega}$$

Gain decreases with $1/\omega$

$$\angle I(j\omega) = -90^\circ$$

Phase is a constant -90°

$$|I(jI_0)| = 1$$

Unity Gain Frequency = I_0

How important is it that an integrator have all 3 of these properties?

Integrator Characteristics of Interest

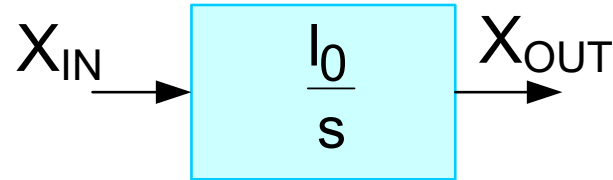

$$I(s) = \frac{I_0}{s}$$

$$|I(j\omega)| = \frac{I_0}{\omega}$$

$$\angle I(j\omega) = -90^\circ$$

$$|I(jI_0)| = 1$$

How important is it that an integrator have all 3 of these properties?

Consider a filter example:

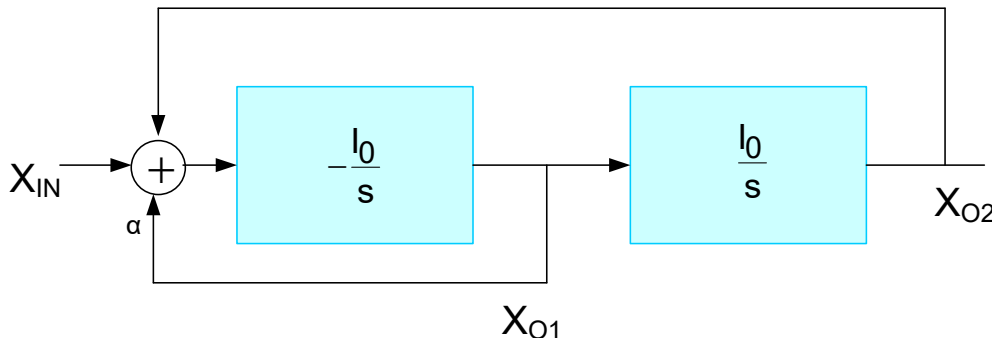

$$T(s) = \frac{-I_0^2}{s^2 + \alpha I_0 s + I_0^2}$$

$$Q = \frac{1}{\alpha} \quad \omega_0 = I_0$$

Band edges proportional to I_0

Phase critical to make Q expression valid

In many (most) applications it is critical that an integrator be very nearly ideal
(in the frequency range of interest)

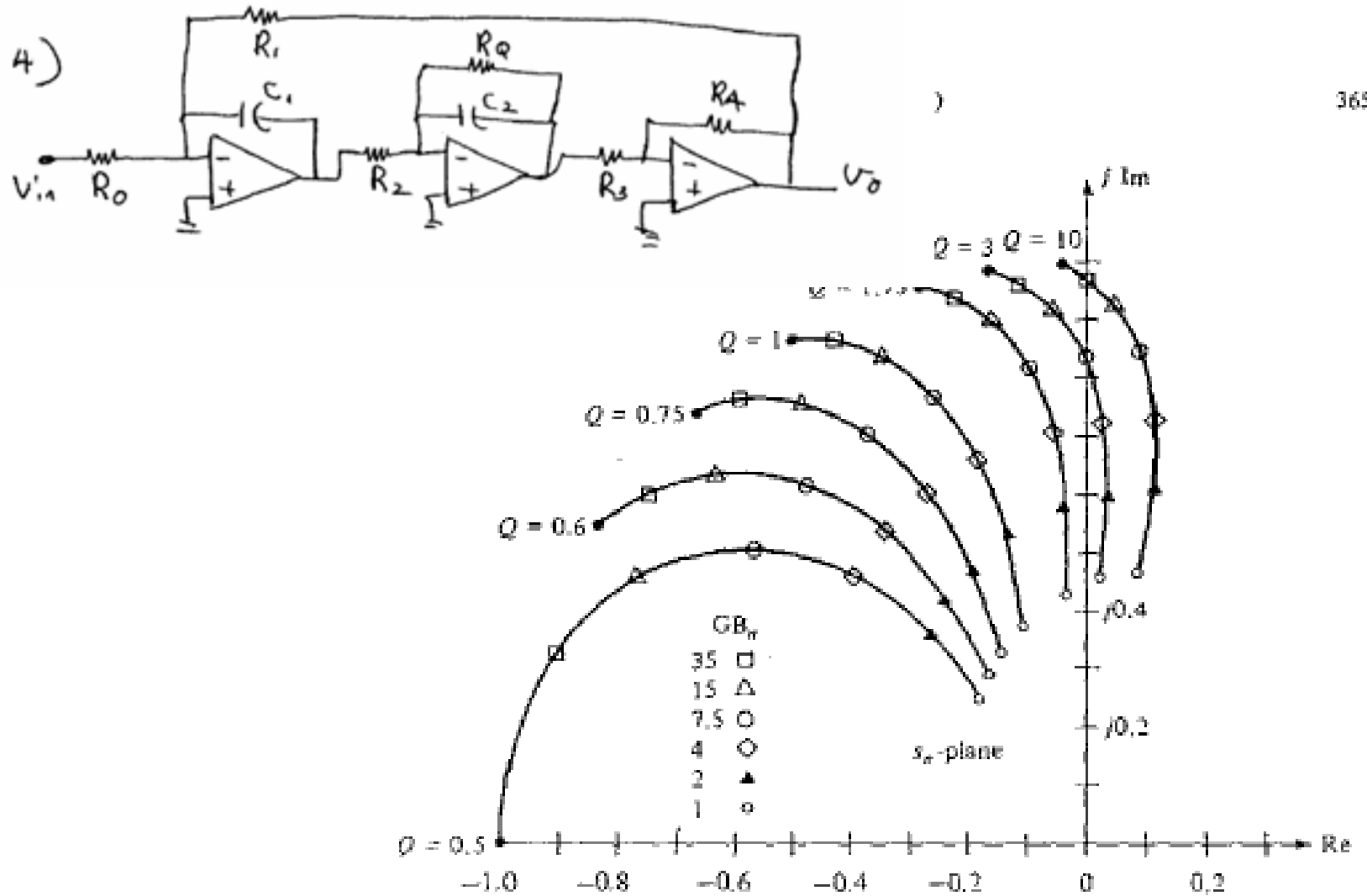
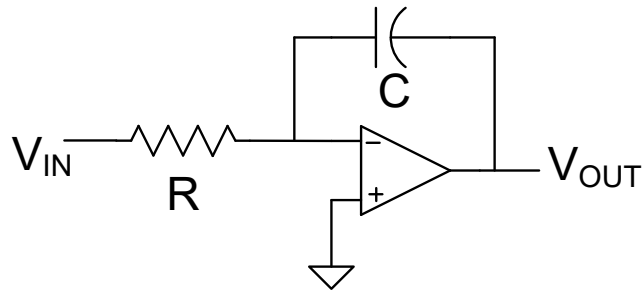

Fig. 10-17 Plot of upper half-plane root of

$$s^2 + s^2 \left(\frac{1}{2} + \frac{1}{Q} + \frac{GB_w}{4} \right) + s, \frac{1}{4Q} \left(1 + GB_w \right) + \frac{GB_w}{4} = 0$$

Some integrator structures



$$I(s) = -\frac{1}{RCs}$$

$$I_0 = \frac{1}{RC}$$

Inverting Active RC Integrator

Are there other integrator structures?

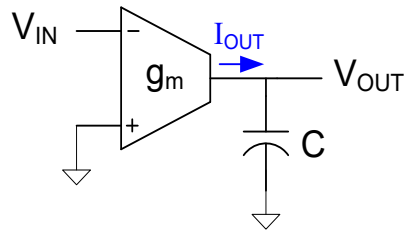

$$\left. \begin{aligned} I_{\text{OUT}} &= -g_m V_{\text{IN}} \\ V_{\text{OUT}} &= I_{\text{OUT}} \frac{1}{sC} \end{aligned} \right\}$$

$$I(s) = -\frac{g_m}{sC}$$

$$I_0 = \frac{g_m}{C}$$

Termed an OTA-C or a gm-C integrator

Some integrator structures

Are there other integrator structures?

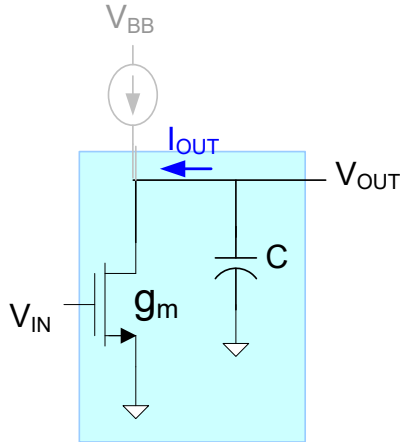

Termed a TA-C integrator

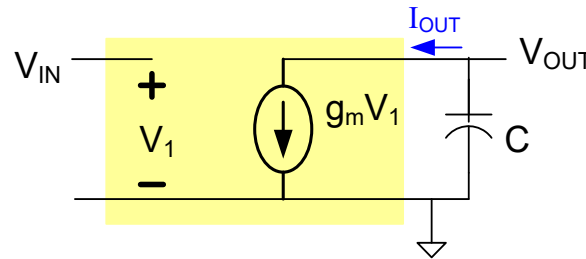

$$\left. \begin{aligned} I_{OUT} &= g_m V_{IN} \\ V_{OUT} &= -I_{OUT} \frac{1}{sC} \end{aligned} \right\} I(s) = -\frac{g_m}{sC}$$

$$I_0 = \frac{g_m}{C}$$

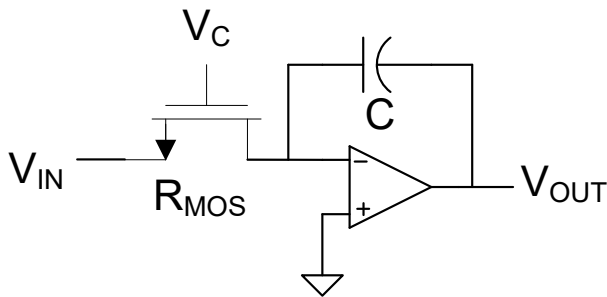

Termed MOSFET-C integrator

$$I(s) = -\frac{1}{sCR_{MOS}}$$

$$I_0 = -\frac{1}{R_{FET}C}$$

Some integrator structures

Are there other integrator structures?

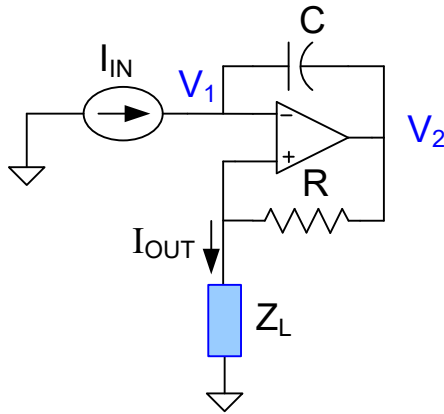

$$\left. \begin{aligned} V_2 &= V_1 - I_{IN} \frac{1}{sC} \\ I_{OUT} &= \frac{V_2 - V_1}{R} \end{aligned} \right\}$$

$$I(s) = \frac{I_{OUT}}{I_{IN}} = -\frac{1}{sRC}$$

$$I_0 = \frac{1}{RC}$$

- Output current is independent of Z_L
- Thus output impedance is ∞ so provides current output

Termed active RC current-mode integrator

Some integrator structures

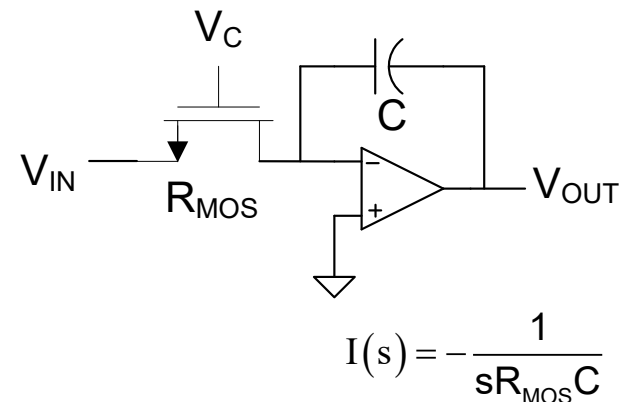
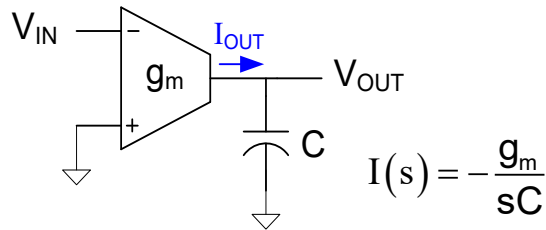
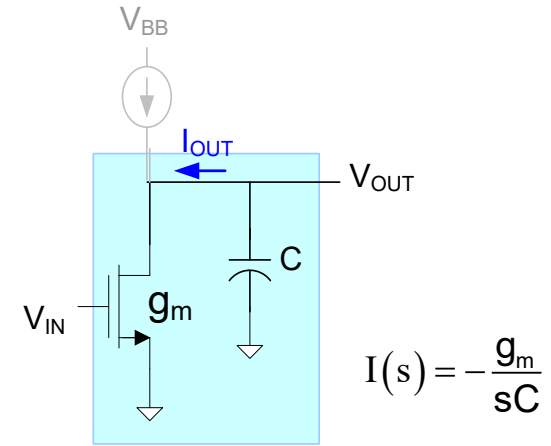
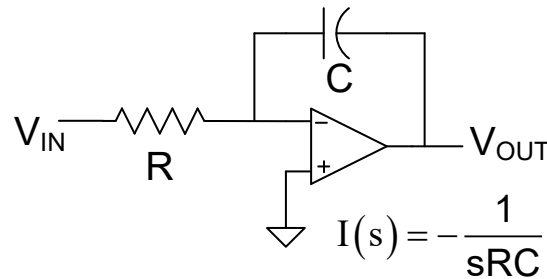
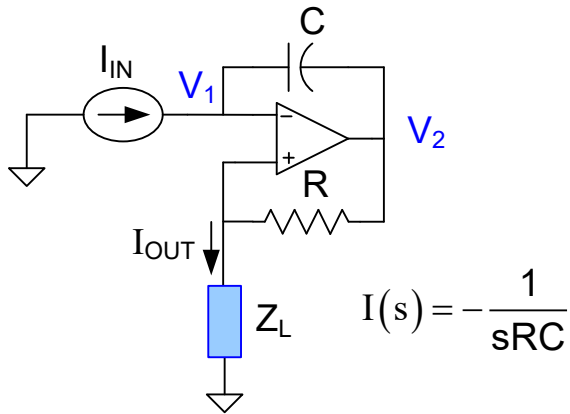

There are other useful integrator structures (some will be introduced later)

There are many different ways to build an inverting integrator

Integrator Functionality

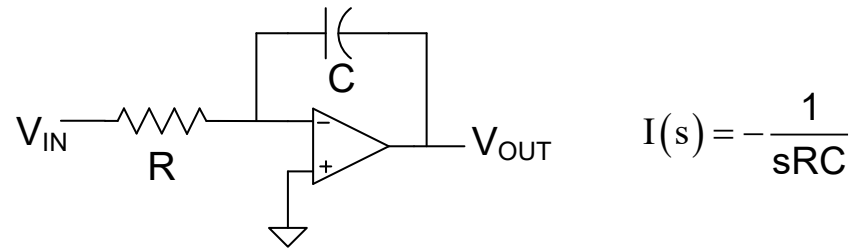

Basic Active RC Inverting Integrator

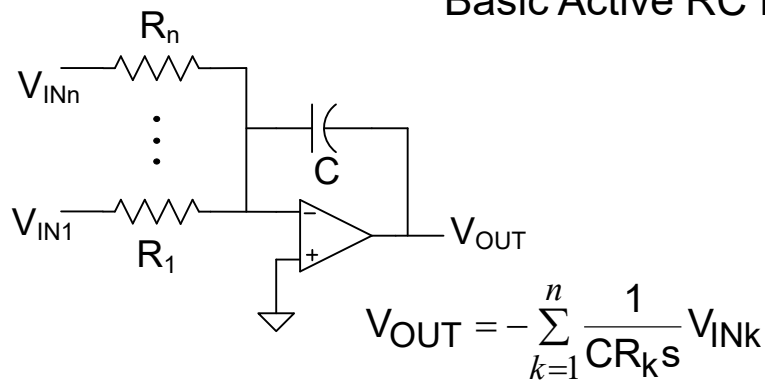

Summing Integrator

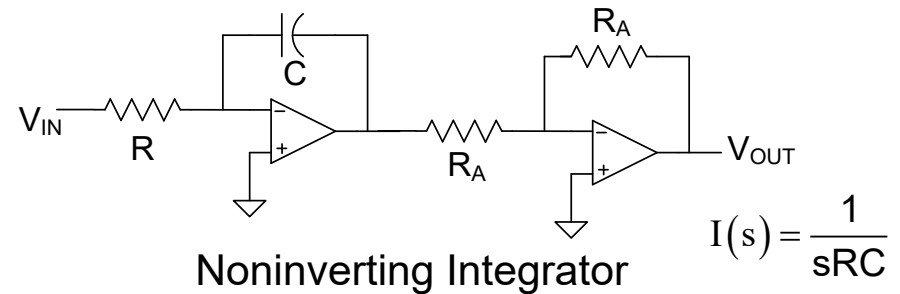

Noninverting Integrator

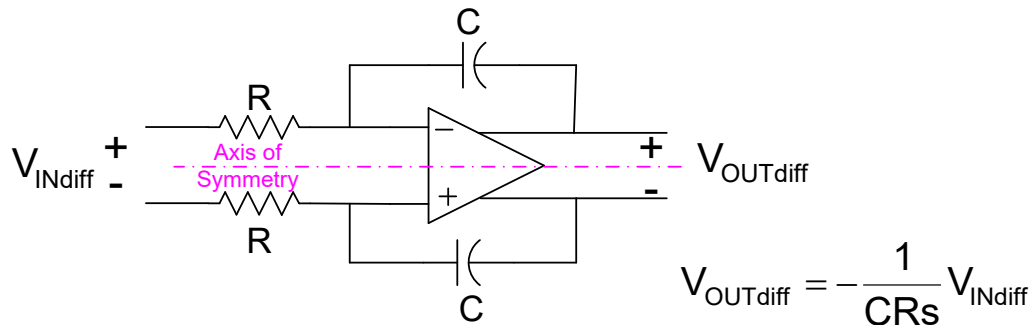

Fully Differential Integrator

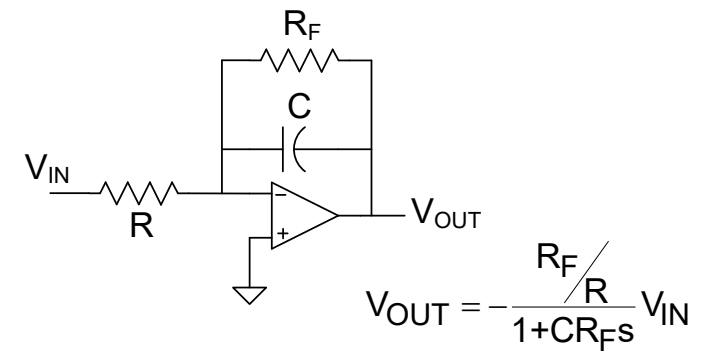

Lossy Integrator

Many different types of functionality from basic inverting integrator
Same modifications exist for other integrator architectures

Integrator-Based Filter Design

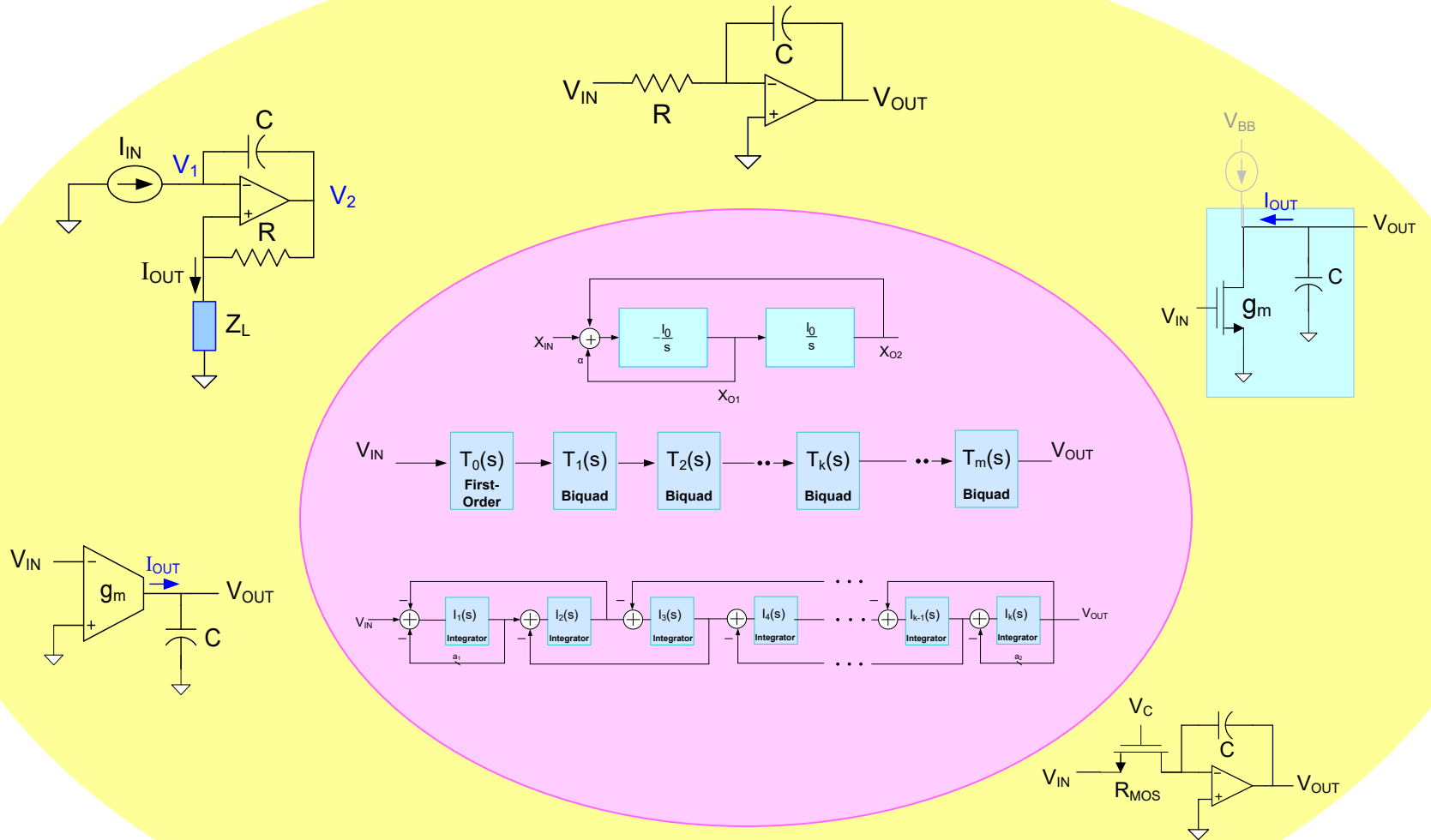

Any of these different types of integrators can be used to build integrator-based filters

Are new integrators still being invented?

Not secure | patft.uspto.gov/netahtml/PTO/search-bool.html

Apps Yahoo Randy Geiger Home CNN - Breaking News Amazon.com: Online Google My eBay Summary GIXEN - Free eBay Auctions Vermont Wooden Toys Google Scholar The Official PVC World Home: Panopto Vimeo

USPTO PATENT FULL-TEXT AND IMAGE DATABASE

[Home](#) [Quick](#) [Advanced](#) [Pat Num](#) [Help](#)

[View Cart](#)

Data current through **October 16, 2018..**

Query [\[Help\]](#)

Term 1: in Field 1:

Term 2: in Field 2:

Select years [\[Help\]](#)

Patents from 1790 through 1975 are searchable only by Issue Date, Patent Number, and Current US Classification.

When searching for specific numbers in the Patent Number field, utility patent numbers are entered as one to eight numbers in length, excluding commas (which are optional, as are leading zeroes).

Searching US Patent Collection...

Results of Search in US Patent Collection db for:

TTL/integrator - 531 patents.

Hits 1 through **50 out of 531**

Jump To

Refine Search

Oct 16 2018

PAT. NO.	Title
1 10,082,922	Increasing the dynamic range of an integrator based mutual-capacitance measurement circuit
2 10,074,004	Capacitive fingerprint sensor with integrator
3 10,070,089	Inverting amplifier, integrator, sample hold circuit, ad converter, image sensor, and imaging apparatus
4 9,985,594	Gated CDS integrator
5 9,972,003	Pregame electronic commerce integrator
6 9,954,514	Output range for interpolation architectures employing a cascaded integrator-comb (CIC) filter with a multiplier
7 9,885,959	Illumination optical apparatus having deflecting member, lens, polarization member to set polarization in circumference direction, and optical integrator
8 9,885,872	Illumination optical apparatus, exposure apparatus, and exposure method with optical integrator and polarization member that changes polarization state of light
9 9,866,237	Low power switched capacitor integrator, analog-to-digital converter and switched capacitor amplifier
10 9,852,283	Confirming the identity of integrator applications
Nov 2017 11 9,825,646	Integrator and A/D converter using the same
12 9,817,917	System integrator and method for mapping dynamic COBOL constructs to object instances for the automatic integration to object-oriented computing systems
13 9,806,552	Analog/digital converter with charge rebalanced integrator
14 9,800,256	Semiconductor device including integrator and successive approximation register analog-to-digital converter and driving method of the same
15 9,753,559	Feedback integrator current source, transistor, and resistor coupled to input
16 9,726,521	Signal processing apparatus for processing time variant signal with first and second input signals comprising a weighting integrator, a magnitude detector and a gain-adjustable amplifier
17 9,709,242	Shell integrator
18 9,703,178	Projector having a rod integrator with an entrance plane smaller than an area light source
19 9,680,496	Apparatus for overload recovery of an integrator in a sigma-delta modulator
20 9,671,916	Increasing the dynamic range of an integrator based mutual-capacitance measurement circuit
21 9,647,677	Integrator, AD converter, and radiation detection device
22 9,634,688	Integrator, delta-sigma modulator, and communications device
23 9,628,103	Multi-mode discrete-time delta-sigma modulator power optimization using split-integrator scheme
24 9,608,598	Cascaded integrator-comb filter as a non-integer sample rate converter
25 9,588,147	Electronic integrator for Rogowski coil sensors
26 9,574,735	Shell integrator
27 9,558,845	Sampling network and clocking scheme for a switched-capacitor integrator
28 9,531,718	Confirming the identity of integrator applications
29 9,524,054	Integrator and touch sensing system using the same
30 9,519,462	System integrator and method for mapping dynamic COBOL constructs to object instances for the automatic integration to object-oriented computing systems
31 9,496,969	Double integrator pulse wave shaper apparatus, system and method
Nov 2016 32 9,495,563	Analog integrator system and method
33 9,473,075	Dynamic current source for amplifier integrator stages
34 9,467,153	Low power and compact area digital integrator for a digital phase detector
35 9,461,595	Integrator for class D audio amplifier
36 9,454,069	Illumination system having first and second lens arrays including plano-convex lenses wherein some lenses in the second array include a first and a second lens element, projection-type display apparatus, and optical integrator
37 9,405,800	Apparatuses, methods and systems for a universal payment integrator
38 9,389,625	DC-DC converter controller apparatus with dual-counter digital integrator
39 9,383,395	Charge balancing converter using a passive integrator circuit
40 9,379,732	Delta-sigma modulator with reduced integrator requirements
41 9,362,890	Compensation filter for cascaded-integrator-comb decimator
42 9,354,953	System integrator and system integration method with reliability optimized integrated circuit chip selection
43 9,314,389	Therapeutic integrator apparatus
44 9,310,924	Increasing the dynamic range of an integrator based mutual-capacitance measurement circuit
45 9,268,441	Active integrator for a capacitive sense array
46 9,225,351	Current amplifier circuit, integrator, and ad converter
47 9,218,514	Apparatuses and method of switched-capacitor integrator
48 9,171,189	Systems and methods for preventing saturation of analog integrator output
49 9,152,387	System integrator and method for mapping dynamic COBOL constructs to object instances for the automatic integration to object-oriented computing systems
50 9,139,096	One-sided detection and disabling of integrator wind up for speed control in a vehicle

























- 51 [9,063,789](#) **T** [Hybrid cloud integrator plug-in components](#)
- 52 [9,061,592](#) **T** [System and method for detecting power integrator malfunction](#)
- 53 [9,054,731](#) **T** [Integrator output swing reduction](#)
- 54 [9,039,190](#) **T** [Projector having integrator with greater illuminance in offset direction of projection lens and modulator](#)
- 55 [9,037,469](#) **T** [Automated communication integrator](#)
- 56 [9,014,322](#) **T** [Low power and compact area digital integrator for a digital phase detector](#)
- 57 [9,009,697](#) **T** [Hybrid cloud integrator](#)
- 58 [8,995,061](#) **T** [Speckle reduction using lenslet integrator](#)
- 59 [8,988,904](#) **T** [Power supply with integrator for controlling current](#)
- 60 [8,957,363](#) **T** [Differential photodiode integrator circuit for absorbance measurements](#)
- 61 [8,952,749](#) **T** [Filter with combined resonator and integrator](#)
- 62 [8,941,526](#) **T** [Time integrator and DELTA, SIGMA, time-to-digital converter](#)
- 63 [8,937,567](#) **T** [Delta-sigma modulator, integrator, and wireless communication device](#)
- 64 [8,922,290](#) **T** [Pulse width modulator with two-way integrator](#)
- 65 [8,866,532](#) **T** [Passive integrator and method](#)
- 66 [8,866,531](#) **T** [Broadband analog radio-frequency integrator](#)
- 67 [8,860,491](#) **T** [Integrator output swing reduction technique for sigma-delta analog-to-digital converters](#)
- 68 [8,854,107](#) **T** [Integrator circuit with inverting integrator and non-inverting integrator](#)
- 69 [8,851,684](#) **T** [Optical unit including an integrator optical system, and projection display device including the optical unit](#)
- 70 [8,835,827](#) **T** [Current integrator with wide dynamic range](#)
- 71 [8,824,626](#) **T** [Reduced-noise integrator, detector and CT circuits](#)
- 72 [8,816,763](#) **T** [Integrator input error correction circuit and circuit method](#)
- 73 [8,779,831](#) **T** [Integrator](#)
- 74 [8,775,003](#) **T** [Methods and systems for controlling a proportional integrator](#)
- 75 [8,767,343](#) **T** [Disk drive increasing integrator output range to complete seek operation](#)
- 76 [8,724,080](#) **T** [Optical raster element, optical integrator and illumination system of a microlithographic projection exposure apparatus](#)
- 77 [8,704,580](#) **T** [Circuit sharing time delay integrator](#)
- 78 [8,674,864](#) **T** [Integrator and oversampling A/D converter having the same](#)
- 79 [8,665,129](#) **T** [Complex second-order integrator and oversampling A/D converter having the same](#)
- 80 [8,659,343](#) **T** [Calibration for mixed-signal integrator architecture](#)
- 81 [8,653,867](#) **T** [Pulse modulated neural integrator circuit and associated phase locked loop](#)
- 82 [8,639,513](#) **T** [Automated communication integrator](#)
- 83 [8,638,420](#) **T** [Optical integrator, illuminating optical device, exposure apparatus and device manufacturing method](#)
- 84 [8,614,639](#) **T** [Integrator ramp generator with DAC and switched capacitors](#)
- 85 [8,611,013](#) **T** [Optical integrator, illumination optical device, aligner, and method for fabricating device](#)
- 86 [8,587,764](#) **T** [Optical integrator system, illumination optical apparatus, exposure apparatus, and device manufacturing method](#)
- 87 [8,575,988](#) **T** [Mixed-signal integrator architecture](#)
- 88 [8,573,779](#) **T** [Lighting device with plural light sources illuminating distinct regions of integrator](#)
- 89 [8,566,277](#) **T** [System integrator and method for mapping dynamic COBOL constructs to object instances for the automatic integration to object-oriented computing systems](#)
- 90 [8,564,358](#) **T** [Integrator circuit with multiple time window functions](#)
- 91 [8,558,610](#) **T** [Integrator input error correction circuit and circuit method](#)
- 92 [8,536,923](#) **T** [Integrator distortion correction circuit](#)
- 93 [8,526,487](#) **T** [Differential energy difference integrator](#)
- 94 [8,520,307](#) **T** [Optical integrator for an illumination system of a microlithographic projection exposure apparatus](#)
- 95 [8,504,503](#) **T** [Pulse modulated neural integrator circuit](#)
- 96 [8,497,977](#) **T** [Optical integrator, illumination optical system, exposure apparatus, and device manufacturing method](#)
- 97 [8,438,201](#) **T** [Digital fractional integrator](#)
- 98 [8,432,150](#) **T** [Methods for operating an array column integrator](#)
- 99 [8,432,149](#) **T** [Array column integrator](#)
- 100 [8,422,018](#) **T** [Optical measurement apparatus including hemispherical optical integrator](#)

July 2014

























Oct 16 2012

PAT. NO.	Title
1 8,290,897	System integrator and method for mapping dynamic COBOL constructs to object instances for the automatic integration to object-oriented computing systems
2 8,283,966	Integrator circuit
3 8,275,307	Vehicle audio integrator
4 8,264,388	Frequency integrator with digital phase error message for phase-locked loop applications
5 8,258,990	Integrator, resonator, and oversampling A/D converter
6 8,253,473	Integrated circuit of an integrator with enhanced stability and related stabilization method
7 8,199,038	Active resistance-capacitor integrator and continuous-time sigma-delta modulator with gain control function
8 8,164,873	Integrator and circuit-breaker having an integrator
9 8,145,597	System integrator and method for mapping dynamic COBOL constructs to object instances for the automatic integration to object-oriented computing systems
10 8,129,972	Single integrator sensorless current mode control for a switching power converter
11 8,125,262	Low power and low noise switched capacitor integrator with flexible input common mode range
12 8,098,377	Electric gated integrator detection method and device thereof
13 8,081,098	Integrator, delta-sigma modulator, analog-to-digital converter and applications thereof
14 8,035,439	Multi-channel integrator
15 8,031,404	Fly's eye integrator, illuminator, lithographic apparatus and method
16 8,029,144	Color mixing rod integrator in a laser-based projector
17 8,028,304	Component integrator
18 8,013,657	Temperature compensated integrator
19 8,011,810	Light integrator for more than one lamp
20 7,997,740	Integrator unit
21 7,965,795	Prevention of integrator wind-up in PI type controllers
22 7,965,151	Pulse width modulator with two-way integrator
23 7,954,962	Laser image display, and optical integrator and laser light source package used in such laser image display
24 7,943,893	Illumination optical system and image projection device having a rod integrator uniformizing spatial energy distribution of diffused illumination beam
25 7,933,812	System integrator and commodity roll-up

Apr 26 2011

- 26 [7,932,960](#)  [Integrator array for HUD backlighting](#)
- 27 [7,911,256](#)  [Dual integrator circuit for analog front end \(AFE\)](#)
- 28 [7,907,115](#)  [Digitally synchronized integrator for noise rejection in system using PWM dimming signals to control brightness of cold cathode fluorescent lamp for backlighting liquid crystal display](#)
- 29 [7,905,631](#)  [Illumination system having coherent light source and integrator rotatable transverse the illumination axis](#)
- 30 [7,884,662](#)  [Multi-channel integrator](#)
- 31 [7,880,969](#)  [Optical integrator for an illumination system of a microlithographic projection exposure apparatus](#)
- 32 [7,873,223](#)  [Cognition integrator and language](#)
- 33 [7,834,963](#)  [Optical integrator](#)
- 34 [7,830,197](#)  [Adjustable integrator using a single capacitance](#)
- 35 [RE41,792](#)  [Controllable integrator](#)
- 36 [7,788,309](#)  [Interleaved comb and integrator filter structures](#)
- 37 [7,773,730](#)  [Voice record integrator](#)
- 38 [7,729,577](#)  [Waveguide-optical Kohler integrator utilizing geodesic lenses](#)
- 39 [7,726,819](#)  [Structure for protecting a rod integrator having a light shield plate with an opening](#)
- 40 [7,724,063](#)  [Integrator-based common-mode stabilization technique for pseudo-differential switched-capacitor circuits](#)
- 41 [7,714,634](#)  [Pseudo-differential active RC integrator](#)
- 42 [7,706,072](#)  [Optical integrator, illumination optical device, photolithograph, photolithography, and method for fabricating device](#)
- 43 [7,696,913](#)  [Signal processing system using delta-sigma modulation having an internal stabilizer path with direct output-to-integrator connection](#)
- 44 [7,693,430](#)  [Burst optical receiver with AC coupling and integrator feedback network](#)
- 45 [7,679,540](#)  [Double sampling DAC and integrator](#)
- 46 [7,671,774](#)  [Analog-to-digital converter with integrator circuit for overload recovery](#)
- 47 [7,658,497](#)  [Rod integrator holder and projection type video display](#)
- 48 [7,629,917](#)  [Integrator and cyclic AD converter using the same](#)
- 49 [7,619,550](#)  [Delta-sigma AD converter apparatus using delta-sigma modulator circuit provided with reset circuit resetting integrator](#)
- 50 [7,611,246](#)  [Projection display and optical integrator](#)

Nov 3 2009

PAT. NO.	Title
51	7.605.645  Transconductor, integrator, and filter circuit
52	7.599.631  Burst optical receiver with AC coupling and integrator feedback network
53	7.575.159  Point of sale integrator
54	7.570.032  Regulator with integrator in feedback signal
55	7.565.326  Dialect independent multi-dimensional integrator using a normalized language platform and secure controlled access
56	7.554.400  Integrator and error amplifier
57	7.543.945  Integrator module with a collimator and a compact light source and projection display having the same
58	7.532.145  High resolution and wide dynamic range integrator
59	7.528.818  Digitally synchronized integrator for noise rejection in system using PWM dimming signals to control brightness of light source
60	7.511.648  Integrating/SAR ADC and method with low integrator swing and low complexity
61	7.474.241  Delta-sigma modulator provided with a charge sharing integrator
62	7.471.456  Optical integrator, illumination optical device, exposure device, and exposure method
63	7.454.750  Integrator adaptor and proxy based composite application provisioning method and apparatus
64	7.447.049  Single ended flyback power supply controllers with integrator to integrate the difference between feedback signal a reference signal
65	7.423.729  Method of monitoring the light integrator of a photolithography system
66	7.417.485  Differential energy difference integrator
67	7.415.716  Component integrator
68	7.411.534  Analog-to-digital converter (ADC) having integrator dither injection and quantizer output compensation
69	7.411.198  Integrator circuitry for single channel radiation detector
70	7.395.090  Personal portable integrator for music player and mobile phone
71	7.385.426  Low current offset integrator with signal independent low input capacitance buffer circuit
72	7.379.160  Optical integrator, illumination optical device, exposure apparatus, and exposure method
73	7.352.510  Light-pipe integrator for uniform irradiance and intensity
74	7.345.285  Spectra acquisition system with threshold adaptation integrator
75	7.333.626  Arbitrary coverage angle sound integrator
..	..

- 76 [7,324,654](#) **T** [Arbitrary coverage angle sound integrator](#)
- 77 [7,324,025](#) **T** [Non-integer interpolation using cascaded integrator-comb filter](#)
- 78 [7,315,268](#) **T** [Integrator current matching](#)
- 79 [7,304,592](#) **T** [Method of adding a dither signal in output to the last integrator of a sigma-delta converter and relative sigma-delta converter](#)
- 80 [7,280,405](#) **T** [Integrator-based current sensing circuit for reading memory cells](#)
- 81 [7,262,056](#) **T** [Enhancing intermolecular integration of nucleic acids using integrator complexes](#)
- 82 [7,243,844](#) **T** [Point of sale integrator](#)
- 83 [7,242,333](#) **T** [Alternate sampling integrator](#)
- 84 [7,205,849](#) **T** [Phase locked loop including an integrator-free loop filter](#)
- 85 [7,187,948](#) **T** [Personal portable integrator for music player and mobile phone](#)
- 86 [7,182,468](#) **T** [Dual lamp illumination system using multiple integrator rods](#)
- 87 [7,180,357](#) **T** [Operational amplifier integrator](#)
- 88 [7,170,959](#) **T** [Tailored response cascaded integrator comb digital filter and methodology for parallel integrator processing](#)
- 89 [7,155,470](#) **T** [Variable gain integrator](#)
- 90 [7,152,981](#) **T** [Projection illumination system with tunnel integrator and field lens](#)
- 91 [7,152,084](#) **T** [Parallelized infinite impulse response \(IIR\) and integrator filters](#)
- 92 [7,150,968](#) **T** [Bridging INtegrator-2 \(Bin2\) nucleic acid molecules and proteins and uses therefor](#)
- 93 [7,138,848](#) **T** [Switched capacitor integrator system](#)
- 94 [7,130,764](#) **T** [Robust DSP integrator for accelerometer signals](#)
- 95 [7,102,844](#) **T** [Dual direction integrator for constant velocity control for an actuator using sampled back EMF control](#)
- 96 [7,102,548](#) **T** [Cascaded integrator comb filter with arbitrary integer decimation value and scaling for unity gain](#)
- 97 [7,098,845](#) **T** [Apparatus for generating an integrator timing reference from a local oscillator signal](#)
- 98 [7,098,827](#) **T** [Integrator circuit](#)
- 99 [7,098,718](#) **T** [Tunable current-mode integrator for low-frequency filters](#)
- 100 [7,087,881](#) **T** [Solid state image pickup device including an integrator with a variable reference potential](#)

Aug 8 2006

PAT. NO.	Title
501 4,161,658	Wind turbine generator having integrator tracking
502 4,160,954	Multiple rate discharge circuit for integrator, especially for use in computerized axial tomography
503 4,154,102	Continuous integrator control linkage
504 4,140,062	Differential integrator
505 4,132,923	Circuit for light-integrator-controlled electronic flash unit
506 4,122,528	Integrator circuits for a constant velocity vector generator
507 4,083,365	Dual integrator EEG analyzer
508 4,081,733	Automatic control system with integrator offset
509 4,061,033	Temperature function integrator
510 4,059,751	Logic controlled integrator
511 4,053,746	System and method for operating a steam turbine with digital computer control having integrator limit
512 4,042,842	Multiple-time-constant integrator or differentiator
513 4,035,809	Electronic integrator for chart recorder
514 4,030,038	Multiple dumping integrator
515 4,023,019	Automatic scaled digital integrator
516 4,012,730	Doppler detection device with integrator sampling means to inhibit false alarms
517 4,006,415	Fast reset integrator
518 4,006,317	Electrostatic transducer and acoustic and electric signal integrator
519 4,002,067	Low friction absolute pressure continuous integrator
520 4,001,721	Field effect transistor Miller integrator oscillator with temperature compensating impedance
521 3,991,730	Noise immune reset circuit for resetting the integrator of an electronic engine spark timing controller
522 3,990,073	Digital signal processing arrangement using a cascaded integrator function generator
523 3,989,961	Bidirectional reset integrator converter
524 3,980,865	Electronic integrator for gas volume calculations
525 3,975,682	Watt/watthour transducer and integrator and current sources therefor
526 3,971,993	High capacity recirculating delay loop integrator
527 3,961,173	Heat unit integrator for X-ray tubes
528 3,946,609	Barometrically compensated pressure index continuous integrator for measuring throughput fluid flow of meters
529 3,943,456	Signal generator for electronic musical instrument, employing variable rate integrator
530 3,942,131	Low frequency two phase oscillator including variable feedback integrator circuits
531 3,931,619	Overtemperature monitor and integrator apparatus

Jan 1976



Stay Safe and Stay Healthy !

End of Lecture 23